

# TWT-48-HC

■ Worktop Counter Refrigerator, 2 Solid Swing Doors



Dimensions		Build		Technical	
External Width (mm)	1229	Door Description	2 Solid Swing Doors	Temperature Holding	0.5 : 3.3°C
External Depth (mm)	766	Exterior Construction	Stainless steel front & countertop, aluminium sides & rear	Refrigerant	R290
External Height (mm)	1004	Interior Construction	Clear coated aluminium, stainless steel base	Voltage / Frequency / Phase	220-240V/50-60Hz/1
Exclusions	Depth does not include 26 mm for rear bumpers.	Air Intake Position	Front	Amps	1
Net Volume (Litres)	278	Ventilation Position	Front	Wattage	230
Gross Volume (Litres)	340	Clearance Required	Zero back and sides	Climate Class	5
Supplied Shelves	4	Cord Length (Meters)	2.13	Operating Statement	Heavy Duty: This appliance is intended for use in ambient temperatures up to 40°C.
Shelf Size (L x D mm)	Two 547 x 514 + Two 547 x 349	Standard w/ Locks	Standard	Testing Standard	EN 16825
Internal Net Height (mm)	630			EEC	A
Unpackaged Weight (kg)	117			EEl	24.1
Packaged Weight (kg)	128			kWh/24hr	1.64
Packaged Dimensions (W x D x H mm)	1296 x 839 x 1207			kWh/Annum	602
Supplied with	ø 127 mm castors (158 mm height)			Defrost Type	Auto



Specifications subject to change without notice.  
Chart dimensions rounded up to the next whole millimeter (inches rounded up to the 1/8")

UK & Ireland [0800 783 2049](tel:08007832049)  
EMEA [+41 61 563 07 05](tel:+41615630705)  
Australia [+61 2 9619 9999](tel:+61296199999)

[TFIUK@truemfg.com](mailto:TFIUK@truemfg.com)  
[TrueCHCustomerService@truemfg.com](mailto:TrueCHCustomerService@truemfg.com)  
[TrueRefAus@truemfg.com](mailto:TrueRefAus@truemfg.com)



# TWT-48-HC

Worktop Counter Refrigerator, 2 Solid Swing Doors

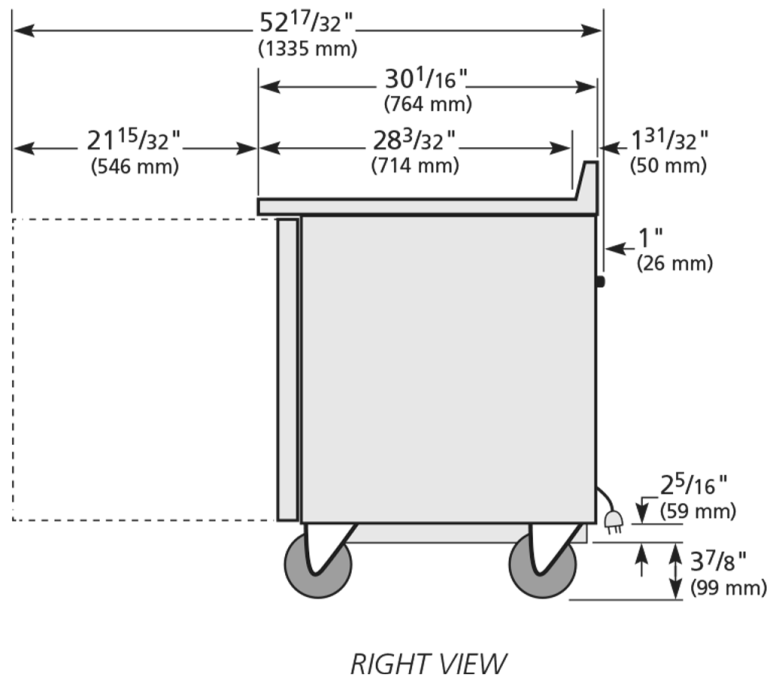
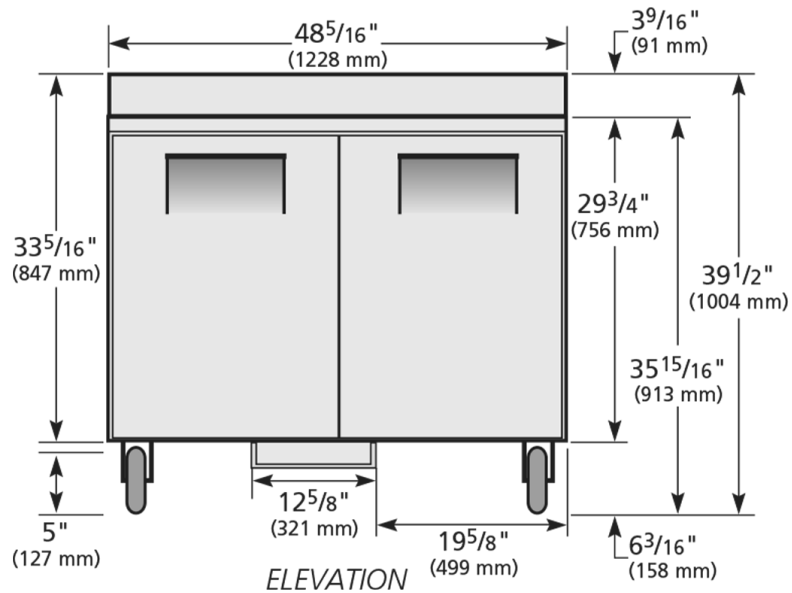

Specifications subject to change without notice.  
Chart dimensions rounded up to the next whole millimeter (inches rounded up to the 1/8")

UK & Ireland [0800 783 2049](tel:08007832049)  
 EMEA [+41 61 563 07 05](tel:+41615630705)  
 Australia [+61 2 9619 9999](tel:+61296199999)

[TFIUK@truemfg.com](mailto:TFIUK@truemfg.com)  
[TrueCHCustomerService@truemfg.com](mailto:TrueCHCustomerService@truemfg.com)  
[TrueRefAus@truemfg.com](mailto:TrueRefAus@truemfg.com)

