

# **OPERATOR'S MANUAL**



## **Model 428 Shake/Slush Freezer**

**Original Operating Instructions**

055058-M

February 2001 (Original Publication)  
(Updated 4/1/2020)

**Complete this page for quick reference when service is required:**

Taylor distributor: \_\_\_\_\_

Address: \_\_\_\_\_

Phone: \_\_\_\_\_

Service: \_\_\_\_\_

Parts: \_\_\_\_\_

Date of installation: \_\_\_\_\_

**Information found on the data label:**

Model Number: \_\_\_\_\_

Serial Number: \_\_\_\_\_

Electrical Specs:           Voltage \_\_\_\_\_ Cycle \_\_\_\_\_

                                  Phase \_\_\_\_\_

Maximum Fuse Size: \_\_\_\_\_ A

Minimum Wire Ampacity: \_\_\_\_\_ A

**Note:** Continuing research results in steady improvements; therefore, information in this manual is subject to change without notice.

**Note:** Only instructions originating from the factory or its authorized translation representative(s) are considered to be the original set of instructions.

© 2001 Taylor Company.  
055058-M

Any unauthorized reproduction, disclosure, or distribution of copies by any person of any portion of this work may be a violation of copyright law of the United States of America and other countries, could result in the awarding of statutory damages of up to \$250,000 (17 USC 504) for infringement, and may result in further civil and criminal penalties. All rights reserved.



Taylor Company  
750 N. Blackhawk Blvd.  
Rockton, IL 61072

## Section 1: To the Installer

- Installer Safety . . . . . 1-1
- Site Preparation . . . . . 1-1
- Air-Cooled Machine. . . . . 1-1
- Electrical Connections. . . . . 1-2
- Refrigerant . . . . . 1-3

## Section 2: To the Operator

- Compressor Warranty Disclaimer . . . . . 2-1

## Section 3: Safety

## Section 4: Operator Parts Identification

- Model 428 . . . . . 4-1
- Beater Door Assembly with Standard Door (No Prime Plug) . . . . . 4-2
- Beater Door Assembly with Self-Closing/Prime Plug Door . . . . . 4-3
- Accessories. . . . . 4-5

## Section 5: User Interface

- Power Switch . . . . . 5-2
- Display Light Switch . . . . . 5-2
- Viscosity Adjustment. . . . . 5-2
- Indicator Light—ADD MIX. . . . . 5-2
- Indicator Light—MIX OUT. . . . . 5-2
- Standby Switch—(Toggle Switch). . . . . 5-2
- Reset Mechanism . . . . . 5-2

## Section 6: Operating Procedures

- Assembly. . . . . 6-1
- Sanitizing. . . . . 6-9
- Priming the Freezing Cylinder. . . . . 6-10
- Closing Procedure. . . . . 6-10
- Draining Product from the Freezing Cylinder . . . . . 6-11
- Rinsing . . . . . 6-11
- Cleaning . . . . . 6-11
- Disassembly . . . . . 6-11
- Brush-Cleaning . . . . . 6-12

**Section 7: Operator Checklist**

During Cleaning and Sanitizing . . . . .7-1  
Troubleshooting Bacterial Count. . . . .7-1  
Regular Maintenance Checks . . . . .7-1  
Winter Storage . . . . .7-2

**Section 8: Troubleshooting Guide**

**Section 9: Parts Replacement Schedule**

**Section 10: Limited Warranty on Equipment**

**Section 11: Limited Warranty on Parts**

The following information has been included in the manual as safety and regulatory guidelines. For complete installation instructions, please see the Operator Checklist.

## Installer Safety



**IMPORTANT!** In all areas of the world, equipment should be installed in accordance with existing local codes. Please contact your local authorities if you have any questions.

Care should be taken to ensure that all basic safety practices are followed during the installation and servicing activities related to the installation and service of Taylor® equipment.

- Only Taylor service personnel should perform installation, maintenance, and repairs on Taylor machines.
- Authorized service personnel should consult OSHA Standard 29CFR1910.147 or the applicable code of the local area for the industry standards on lockout/tagout procedures before beginning any installation or repairs.
- Authorized service personnel must ensure that the proper protective equipment (PPE) is available and worn when required during installation and service.
- Authorized service personnel must remove all metal jewelry, rings, and watches before working on electrical equipment.



**DANGER!** The main power supply(s) to the machine must be disconnected prior to performing any installation, maintenance, or repairs. Failure to follow this instruction may result in personal injury or death from electrical shock or hazardous moving parts, as well as poor performance or damage to the machine.

**Note:** All repairs must be performed by a Taylor service technician.



**WARNING!** This machine has many sharp edges that can cause severe injuries.

## Site Preparation

Review the area the machine is to be installed in before uncrating the machine, making sure that all possible hazards to the user or machine have been addressed.

## Air-Cooled Machine

Air-cooled machines require a minimum of 3 in. (76 mm) of clearance on both sides of the freezer. It is recommended to place the rear of the machine against the wall to prevent the recirculation of warm air. Minimum air clearances must be met to ensure adequate airflow for optimum performance. Failure to allow adequate clearance can reduce the refrigeration capacity of the freezer and possibly cause permanent damage to the compressor.

**For Indoor Use Only:** This machine is designed to operate indoors under normal ambient temperatures of 70°F to 75°F (21°C to 24°C). The freezer has successfully performed in high ambient temperatures of 104°F (40°C) at reduced capacities.



**WARNING!** This machine must **NOT** be installed in an area where a water jet or hose can be used. **NEVER** use a water jet or hose to rinse or clean the machine. Failure to follow this instruction may result in electrocution.



**CAUTION!** This machine must be installed on a level surface to avoid the hazard of tipping. Extreme care should be taken in moving this equipment for any reason. Two or more persons are required to safely move this machine. Failure to comply may result in personal injury or equipment damage.

Uncrate the machine and inspect it for damage. Report any damage to your Taylor distributor.

This piece of equipment is made in the USA and has

USA sizes of hardware. All metric conversions are approximate and vary in size.

### Electrical Connections

1

This equipment is supplied with a three-wire cord and grounding type of plug for connection to a single-phase, 60-cycle, branch circuit supply. This machine must be plugged into a properly grounded receptacle. The cord and plug provided are 20A for 115/60/1 or 15A for 208-230/60/1. Therefore, the wall outlet must also be 20A for 115/60/1 or 15A for 208-230/60/1. See the data label on the side panel for electrical specifications.

**Note:** *The following procedures should be performed by a Taylor service technician.*

Permanent wiring may be employed if required by local codes. Instructions for conversion to permanent wiring are as follows:

1. Make sure the freezer is electrically disconnected.
2. Remove the appropriate panel and locate the small electrical box at the base of the freezer.
3. Remove the factory-installed cord and strain relief bushing.
4. Route incoming permanent wiring through the 7/8 in. (22 mm) hole in the base pan.
5. Connect two power supply leads. Attach ground (earth) wire to the grounding lug inside the electrical box.
6. Make sure the machine is properly grounded before applying power.

In the United States, this machine is intended to be installed in accordance with the National Electrical Code (NEC), ANSI/NFPA 70-1987. The purpose of the NEC code is the practical safeguarding of persons and property from hazards arising from the use of electricity. This code contains provisions considered necessary for safety. In all other areas of the world, machines should be installed in accordance with the existing local codes. Please contact your local authorities.



Each machine requires one power supply for each data label on the machine. Check the data label(s) on the freezer for branch circuit overcurrent protection or fuse, circuit ampacity, and other electrical specifications.

See the wiring diagram provided inside the electrical box for proper power connections.



**WARNING!** This equipment must be properly grounded. Failure to do so can result in severe personal injury from electrical shock.



**WARNING! DO NOT** operate this machine with fuses larger than specified on the machine data label. Failure to follow this instruction may result in electrocution or damage to the machine.



**IMPORTANT!** *An equipotential grounding lug is provided with this machine. Some countries require the grounding lug be properly attached to the rear of the frame by the authorized installer. The installation location is marked by the equipotential bonding symbol (5021 of IEC 60417-1) on both the removable panel and the machine's frame.*



**IMPORTANT!**

- *Stationary appliances which are not equipped with a power cord and a plug or another device to disconnect the appliance from the power source must have an all-pole disconnecting device with a contact gap of at least 0.125 in. (3 mm) installed in the external installation.*
- *Machines that are permanently connected to fixed wiring and for which leakage currents may exceed 10 mA, particularly when disconnected or not used for long periods, or during initial installation, shall have protective devices to protect against the leakage of current, such as a GFI, installed by the authorized personnel to the local codes.*
- *Supply cords used with this machine shall be oil-resistant, sheathed flexible cable not lighter than ordinary polychloroprene or other*

*equivalent synthetic elastomer-sheathed cord (code designation 60245 IEC 57) installed with the proper cord anchorage to relieve conductors from strain, including twisting, at the terminals and protect the insulation of the conductors from abrasion.*

- *If the supply cord is damaged, it must be replaced by a Taylor service technician to avoid a hazard.*

## Beater Rotation



Beater rotation must be clockwise as viewed looking into the freezing cylinder.

**Note:** *The following procedures must be performed by a Taylor service technician.*

To correct rotation on a single-phase machine, change the leads inside the beater motor. (Follow the diagram printed on the motor.)

## Refrigerant



**CAUTION!** This equipment contains fluorinated greenhouse gases (F-Gas) to provide refrigeration using a hermetically sealed circuit or within foam insulation. This machine's type of gas, quantity, Global Warming Potential (GWP), and CO<sub>2</sub> tonnes equivalent information is recorded on the machine's data label. The refrigerant used is generally considered nontoxic and nonflammable. However any gas under pressure is potentially hazardous and must be handled with caution.

**NEVER** fill any refrigerant cylinder completely with liquid. Filling the cylinder to approximately 80% will allow for normal expansion.



**CAUTION!** Use only approved refrigerant listed on the machine's data label or authorized through a manufacturer's technical bulletin. The use of any other refrigerant may expose users and operators to unexpected safety hazards.



**WARNING!** Refrigerant liquid sprayed onto the skin may cause serious damage to tissue. Keep eyes and skin protected. If refrigerant burns should occur, flush immediately with cold water. If burns are severe, apply ice packs and contact a physician immediately.



**NOTICE!** Taylor reminds technicians to be aware of and in compliance with local government laws regarding refrigerant recovery, recycling, and reclaiming systems. For information regarding applicable local laws, please contact your local Taylor distributor.



**IMPORTANT!** *Refrigerants and their associated lubricants may be extremely moisture absorbent. When opening a refrigeration system, the maximum time the system is open must not exceed 15 minutes. Cap all open tubing to prevent humid air or water from being absorbed by the oil.*





The freezer you have purchased has been carefully engineered and manufactured to give you dependable operation. The Taylor Model 428, when properly operated and cared for, will produce a consistent quality product. Like all mechanical products, it will require cleaning and maintenance. A minimum amount of care and attention is necessary if the operating procedures outlined in this manual are followed closely.

This Operator's Manual should be read before operating or performing any maintenance on your machine.

Your Taylor freezer will **not** eventually compensate for and correct any errors during the setup or filling operations. Thus, the initial assembly and priming procedures are of extreme importance. It is strongly recommended that personnel responsible for the machine's operation, both assembly and disassembly, go through these procedures together to be properly trained and to make sure no misunderstandings exist.

In the event you should require technical assistance, please contact your local Taylor distributor.

**Note:** *Your Taylor warranty is valid only if the parts are authorized Taylor parts, purchased from the local authorized Taylor distributor, and only if all required service work is provided by a Taylor service technician. Taylor reserves the right to deny warranty claims on machines or parts if unapproved parts or incorrect refrigerant were installed in the machine, system modifications were performed beyond factory recommendations, or it is determined that the failure was caused by abuse, misuse, neglect, or failure to follow all operating instructions. For full details of your Taylor warranty, please see the Limited Warranty section in this manual.*

**Note:** *Constant research results in steady improvements. Therefore, information in this manual is subject to change without notice.*



**IMPORTANT!** *If the crossed-out, wheeled-bin symbol is affixed to this machine, it signifies that this machine is compliant with the EU Directives as well as other similar end-of-life legislation in effect after August*

*13, 2005. Therefore, it must be collected separately after its use is completed and cannot be disposed as unsorted municipal waste.*

*The user is responsible for returning the machine to the appropriate collection facility, as specified by your local code.*

*For additional information regarding applicable local disposal laws, please contact the municipal waste facility and/or local authorized Taylor distributor.*

## Compressor Warranty Disclaimer

The refrigeration compressor(s) on this machine are warranted for the term stated in the Limited Warranty section in this manual. However, due to the Montreal Protocol and the U.S. Clean Air Act Amendments of 1990, many new refrigerants are being tested and developed, thus seeking their way into the service industry. Some of these new refrigerants are being advertised as drop-in replacements for numerous applications. It should be noted that in the event of ordinary service to this machine's refrigeration system, **only the refrigerant specified on the affixed data label should be used.** The unauthorized use of alternate refrigerants will void your Taylor compressor warranty. It is the machine owner's responsibility to make this fact known to any technician he/she employs.

It should also be noted that Taylor does not warrant the refrigerant used in its equipment. For example, if the refrigerant is lost during the course of ordinary service to this machine, Taylor has no obligation to either supply or provide its replacement either at billable or unbillable terms. Taylor does have the obligation to recommend a suitable replacement if the original refrigerant is banned, obsolete, or no longer available during the 5-year warranty of the compressor.

Taylor will continue to monitor the industry and test new alternates as they are being developed. Should a new alternate prove, through our testing, that it would be accepted as a drop-in replacement, then the above disclaimer would become null and void. To find out the current status of an alternate refrigerant as it relates to your compressor warranty, call the local Taylor distributor or the Taylor factory. Be prepared to provide the model/serial number of the machine in question.



We at Taylor Company are concerned about the safety of operators at all times when they are coming in contact with the machine and its parts. Taylor makes every effort to design and manufacture built-in safety features to protect both operators and service technicians.

Installing and servicing refrigeration equipment can be hazardous due to system pressure and electrical components. Only trained and qualified service personnel should install, repair, or service refrigeration equipment. When working on refrigeration equipment, observe precautions noted in the literature, tags, and labels attached to the machine, and other safety precautions that may apply. Follow all safety code requirements. Wear safety glasses and work gloves.



**DANGER!** Failure to adhere to the following safety precautions may result in severe personal injury or death. Failure to comply with these warnings may also damage the machine and/or its components. Such damage may result in component replacement and service repair expenses.



**NOTICE! DO NOT** operate the machine without reading this entire manual first. Failure to follow all of these operating instructions may result in damage to the machine, poor performance, health hazards, or personal injury.



**IMPORTANT!** *This machine is to be used only by trained personnel. It is not intended for use by children or people with reduced physical, sensory, or mental capabilities, or lack of experience and knowledge. Where limited equipment operation is allowed for public use, such as a self-serve application, supervision or instruction concerning the use of the appliance by a person responsible for their safety is required. Children should be supervised to ensure that they do not play with the machine.*



**WARNING! DO NOT** use a water jet to clean or rinse the machine. Failure to follow these instructions may result in serious electrical shock.



**WARNING!** Avoid injury.

- **DO NOT** operate the machine unless it is properly grounded.
- **DO NOT** operate the machine with fuses larger than specified on the machine's data label.
- All repairs should be performed by a Taylor service technician.
- Cord-connected machines: Only Taylor service technicians may install a plug on this machine.
- The main power supplies to the machine must be disconnected prior to performing installation, repairs, or maintenance.
- Machines that are permanently connected to fixed wiring and for which leakage currents may exceed 10 mA, particularly when disconnected or not used for long periods, or during initial installation, shall have protective devices to protect against the leakage of current, such as a GFI, installed by the authorized personnel to the local codes.
- Stationary machines which are not equipped with a power cord and a plug or another device to disconnect the appliance from the power source must have an all-pole disconnecting device with a contact gap of at least 0.125 in. (3 mm) in the external installation.
- Supply cords used with this machine shall be oil-resistant, sheathed flexible cable not lighter than ordinary polychloroprene or other equivalent synthetic elastomer-sheathed cord (code designation 60245 IEC 57) installed with the proper cord anchorage to relieve conductors from strain, including twisting, at the terminals and protect the insulation of the conductors from abrasion.
- If the supply cord is damaged, it must be replaced by a Taylor service technician to prevent a hazard.

## SAFETY

---

Failure to follow these instructions may result in electrocution. Contact your local authorized Taylor distributor for service.



**IMPORTANT!** This machine is provided with an equipotential grounding lug that is to be properly attached to the rear of the frame by the authorized installer. The installation location is marked by the equipotential bonding symbol (5021 of IEC 60417-1) on both the removable panel and the equipment's frame.



3

**WARNING!** Avoid injury.

- **DO NOT** allow untrained personnel to operate this machine.
- **DO NOT** operate the machine unless all service panels and access doors are fastened with screws.
- **DO NOT** remove any internal operating parts (including, but not limited to, freezer door, beater, or scraper blades) unless all control switches are in the OFF position.

Failure to follow these instructions may result in severe personal injury, especially to fingers or hands, from hazardous moving parts.



**WARNING!** This machine has many sharp edges that can cause severe injuries.

- **DO NOT** put objects or fingers in the door spout. This may contaminate the product and cause severe personal injury from blade contact.
- **USE EXTREME CAUTION** when removing the beater assembly. The scraper blades are very sharp.



**CAUTION!** This machine must be placed on a level surface. Extreme care should be taken when moving the machine for any reason. Two or more persons are required to safely move this machine. Failure to comply may result in personal injury or damage to the machine.



**IMPORTANT!** Access to the service area of the machine must be restricted to persons having knowledge and practical experience with the machine, in particular as far as safety and hygiene are concerned.



**NOTICE!** Cleaning and sanitizing schedules are governed by your federal, state, or local regulatory agencies and must be followed accordingly. Please refer to the cleaning section of this manual for the proper procedure to clean this machine.



**CAUTION!** This machine is equipped with a refrigerated cabinet designed to maintain product temperature at or below 41°F (5°C). Any product being added to this machine must be below 41°F (5°C). Failure to follow this instruction may result in health hazards and poor freezer performance.

**DO NOT** run the machine without product. Failure to follow this instruction can result in damage to the machine.

**DO NOT** obstruct air intake and discharge openings: 3 in. (76 mm) minimum airspace on front, sides and rear, and 3-1/2 in. (89 mm) on bottom.

**For Indoor Use Only:** This machine is designed to operate indoors, under normal ambient temperatures of 70°F to 75°F (21°C to 24°C). The machine has successfully performed in high ambient temperatures of up to 104°F (40°C) at reduced capacities.

**Noise Level:** Airborne noise emission does not exceed 78 dB(A) when measured at a distance of 39 in. (1.0 m) from the surface of the machine and at a height of 62 in. (1.6 m) from the floor.

## Model 428

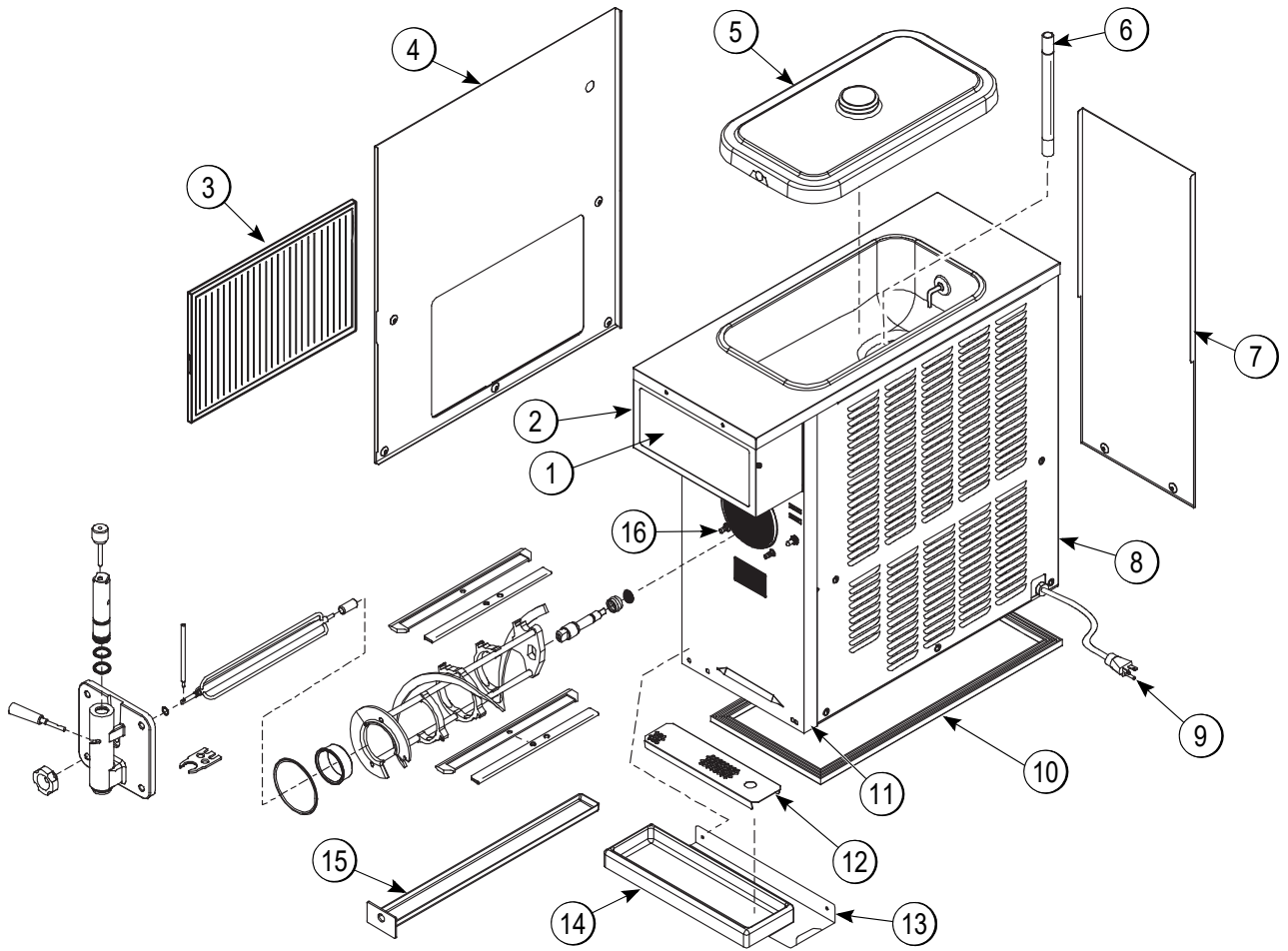

4

Figure 4-1

Item	Description	Part No.
1	Lens-Light	052952
2	Plate A.-DEC Lighted	X52936
3	Filter-Air-17 x 13 x 7/16	052951
4	Panel A.-Side *Left	X62592
5	Cover A.-Hopper	X51152
6	Tube-Feed 5/16 Hole SS	028967-7
7	Panel-Rear	062594
8	Panel -Side *Right	052935

Item	Description	Part No.
9	Cord-Power-125V	045666
10	Gasket-Base Pan-OVRRN	062619
11	Panel-Front	054933
12	Shield-Splash	052980
13	Shelf-Drip Tray	052979
14	Tray-Drip	052978
15	Pan-Drip 22-29/32 Long	053048
16	Stud-Nose-Cone-5/16-18	013496

**Note:** Standard door shown (no prime plug).

Beater Door Assembly with Standard Door (No Prime Plug)

4

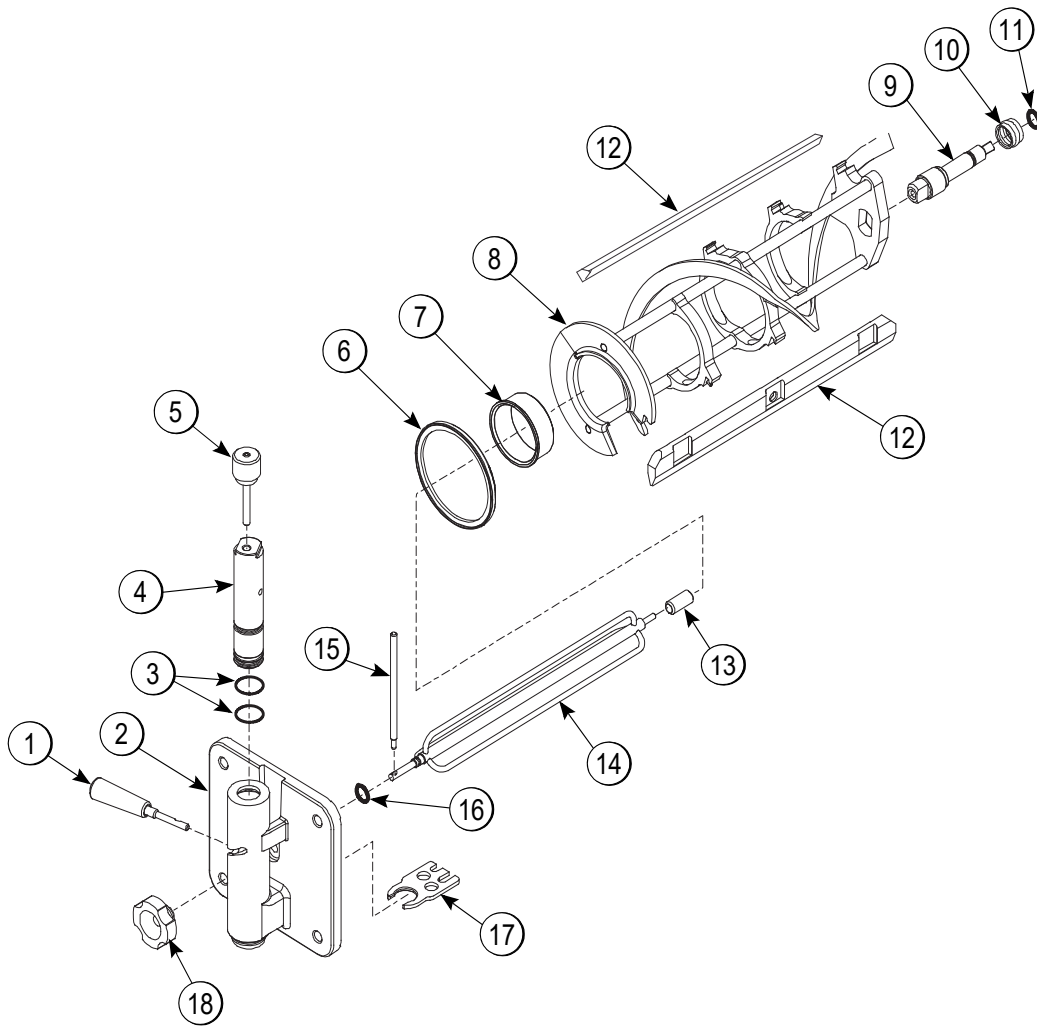

Figure 4-2

Item	Description	Part No.
1	Handle A.-Draw	X47384
2	Door A.-Slush-Partial	X83427SER3
3	O-ring-1"OD x.139W	032504
4	Valve-Draw	047734
5	Pin A.-Valve Handle	X25929
6	Gasket-Door 5.109"ID	014030
7	Bearing-Front	013116
8	Beater A.-7QT-1 Pin	X46233
9	Shaft-Beater	035418

Item	Description	Part No.
10	Seal-Drive Shaft	032560
11	O-ring-7/8 OD x.139W	025307
12	Blade- Scraper- Plastic	084950
13	Bearing-Guide	013116
*14	Torque A.	X14488
15	Arm-Torque	052450
16	O-ring-.291 ID x.080W	018550
17	Buster-Ice	047735
18	Nut-Stud	029880

\*Note: Optional Torque A. = X27027- 1.

Beater Door Assembly with Self-Closing/Prime Plug Door

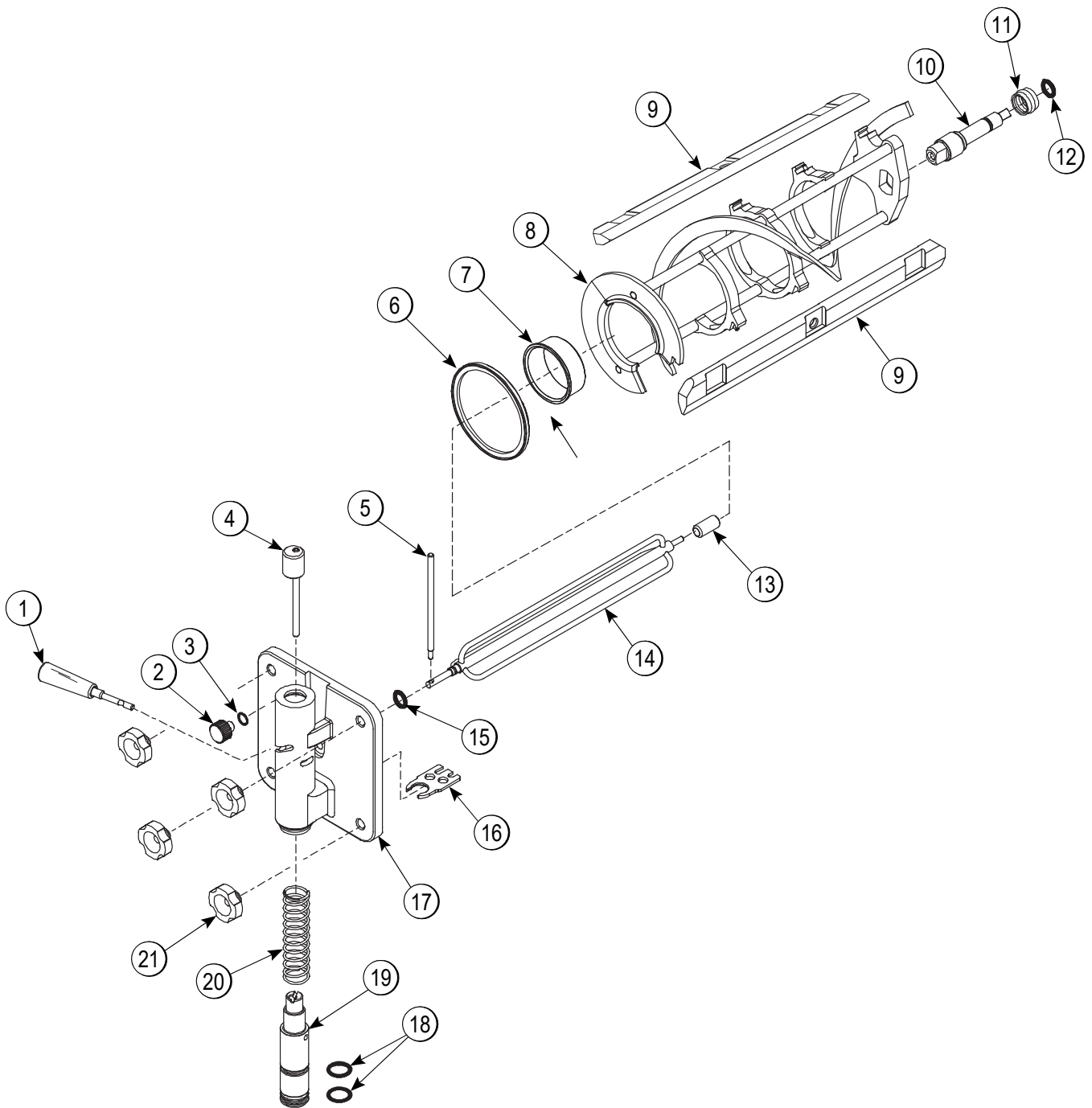

4

Figure 4-3

## OPERATOR PARTS IDENTIFICATION

### Beater Door Assembly With Self-Closing/Prime Plug Door (Cont.)

Item	Description	Part No.
1	Handle A.-Draw-Slush-BLK	X47384
2	Plug-Prime-STNLS	050405
3	O-ring-.563 OD x .070W	043758
4	Pin A.-Valve Handle	X83812
5	Arm-Torque	052450
6	Gasket-Door 5.109"ID	014030
7	Bearing-Front	013116
8	Beater A.-7QT-1 Pin	X46233
9	Blade- Scraper- Plastic	084950
10	Shaft-Beater	035418
11	Seal-Drive Shaft	032560

Item	Description	Part No.
12	O-ring-7/8 OD x.139W	025307
13	Bearing-Guide	014496
14	Torque A.	X14488
15	O-ring-.291 ID x.080W	018550
16	Buster-Ice	047735
17	Door A.-Slush-Partial	X83427SER3
18	O-ring-1"OD x.139W	032504
19	Valve-Draw-SLF Close	080662
20	Spring-Comp.970x.082	030344
21	Nut-Stud	029880

4



Accessories

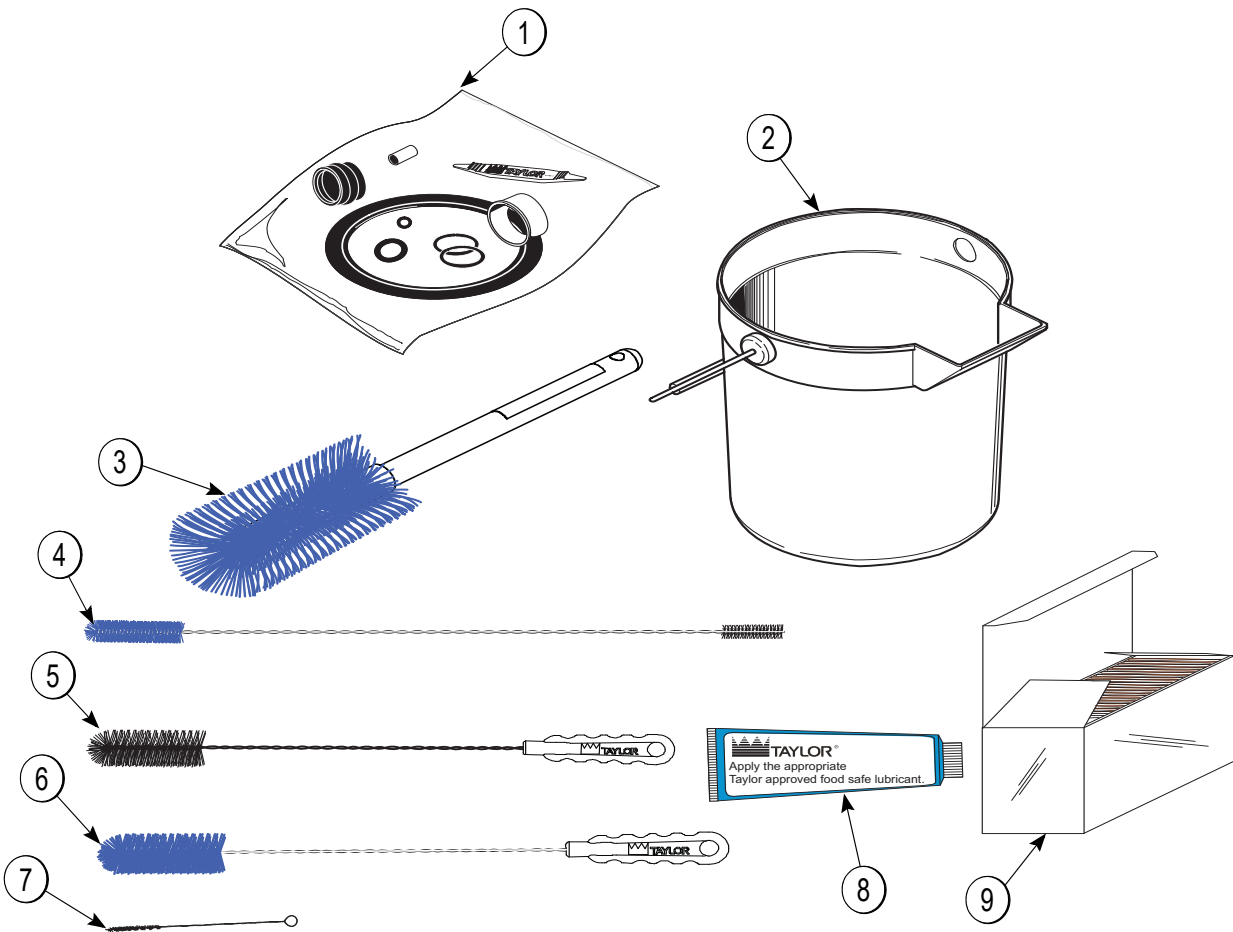

4

Figure 4-4

Item	Description	Part No.
1	Kit A.-Tune Up (Std. Door Units)	X39969
	Kit A.-Tune Up-Torque (Prime Plug, Self-Closing Door Units)	X50413
2	Pail-10 qt.	013163
3	Brush-Mix Pump Body-3" X7"	023316
4	Brush-Double Ended	013072

Item	Description	Part No.
5	Brush-Rear BRG 1" X 2"	013071
6	Brush-Draw Valve 1 x 2 x 17	013073
7	Brush-Syrup Port	045079
8	Lubricant-Taylor 4 oz.	047518
9	Sanitizer-Stera Sheen -Green	055492



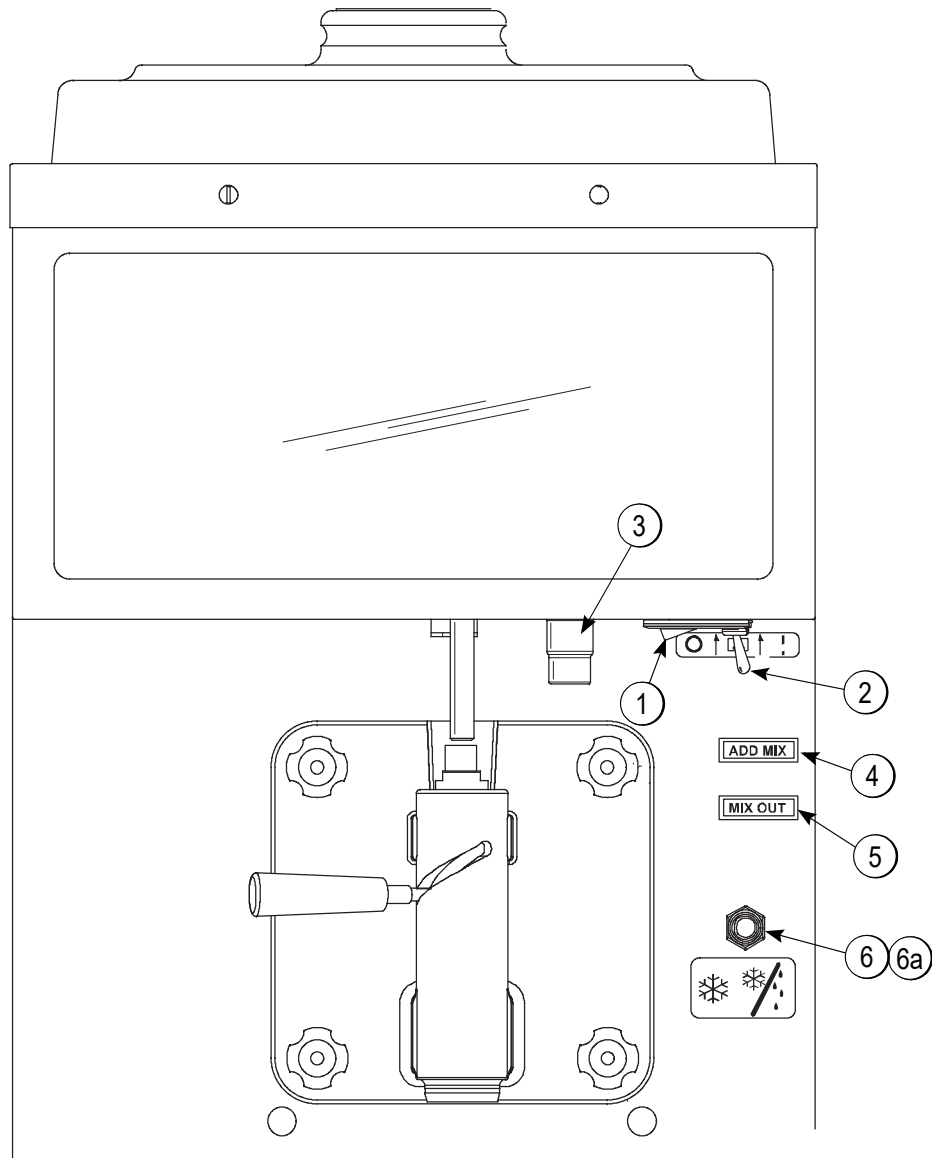

5

Figure 5-1

Item	Description	Part No.
1	Switch- Rocker Auto/Wash (Power Switch)	048420
2	Switch- Toggle- SPST 3/4HP/250V (Display Light)	012626
3	Bushing A.-Torque (Viscosity Adjustment)	X50399- SER

Item	Description	Part No.
4	Light- Amber- Rect-12VDC ADD MIX	052486- 02
5	Light- Amber- Rect-12VDC MIX OUT	052487- 02
6	Switch- Toggle- SPST 3/4 HP/250V (Standby Switch)	012626
6a	Boot- Switch- Toggle	043398

NOTE: Standard door shown (no prime plug)

### Power Switch

The center position is OFF. The right position is AUTO, which activates the beater motor and the refrigeration system. The left position is WASH, which activates the beater motor only.

### Display Light Switch

The display light switch is under the control channel. The left position is OFF. The right position is ON and activates the display light.

### Viscosity Adjustment

The viscosity (thickness) of the product can be adjusted by turning the viscosity adjustment screw on the right side of the machine, under the display light. Turn the viscosity adjustment screw clockwise for a thicker product, or counterclockwise for a thinner product. After making an adjustment, allow the refrigeration system to cycle two or three times to accurately evaluate the viscosity.

## 5 Indicator Light—ADD MIX

An ADD MIX indicator light is on the front of the machine. The light flashes to indicate when the mix hopper has a low supply of product and should be refilled as soon as possible.

### Indicator Light—MIX OUT

A MIX OUT indicator light is on the front of the machine. When the light is flashing, it indicates that the hopper is empty and the mix supply needs replenishing. To prevent damage to the machine, refrigeration discontinues automatically when the MIX OUT indicator light is flashing.

### Standby Switch—(Toggle Switch)

This switch determines which mode of operation the freezing cylinder is operating in. The left position places the machine in the Auto mode. The right position places the machine in the Standby mode.

**Note:** The power switch must be in the AUTO position for the Standby switch to function.

### Reset Mechanism

Should an overload condition occur, the freezer will automatically shut down. To properly reset the freezer, place the toggle switch in the OFF position. Wait 2 or 3 minutes, then press the RESET button located in the left side panel. Place the toggle switch in the WASH position and observe the freezer's performance. Return the toggle switch to the AUTO position.



**CAUTION! DO NOT** use metal objects to press the RESET button. Failure to follow this instruction may result in electrocution.

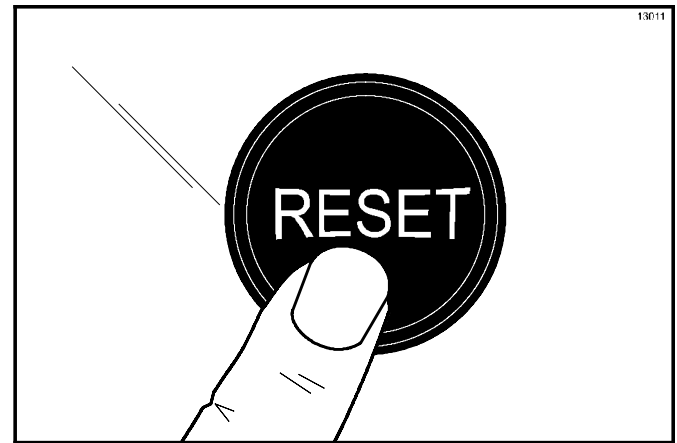

Figure 5-2

The Model 428 freezer is designed to produce shake or slush product at the desired thickness. This machine has a 7 qt. (6.6 L) freezing cylinder.

We begin our instructions at the point when we enter the store in the morning and find the parts disassembled and laid out to air-dry from the previous night's brush-cleaning.

These opening procedures will show you how to assemble these parts into the freezer, sanitize them, and prime the freezer with **fresh** mix in preparation to serve your first portion.

If you are disassembling the machine for the first time or need information to get to this point in our instructions, turn to Disassembly on page 6-11 and start there.

## Assembly

**Note:** When lubricating parts, use an approved food grade lubricant (example: Taylor Lube).

1. Slide the O-ring into the groove on the driveshaft. Lubricate the O-ring and shaft portion that comes in contact with the bearing. **Do not** lubricate the square end of the driveshaft.

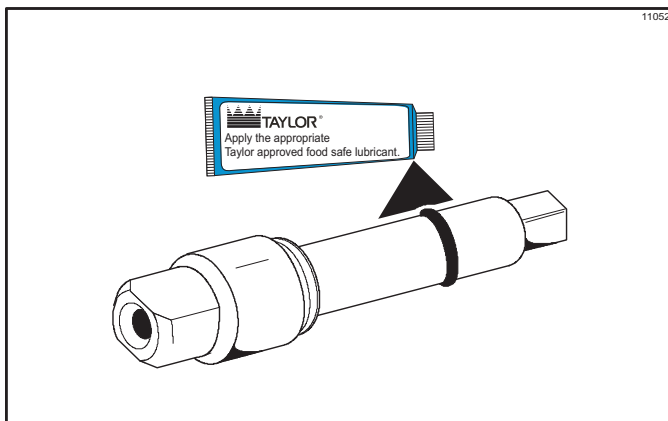

Figure 6-1

**Note:** To ensure that the mix does not leak out of the back of the freezing cylinder, the middle section of the boot seal should be convex, or extend out from the seal. If the middle section of the boot seal is concave, or extending into the middle of the seal, invert the seal.

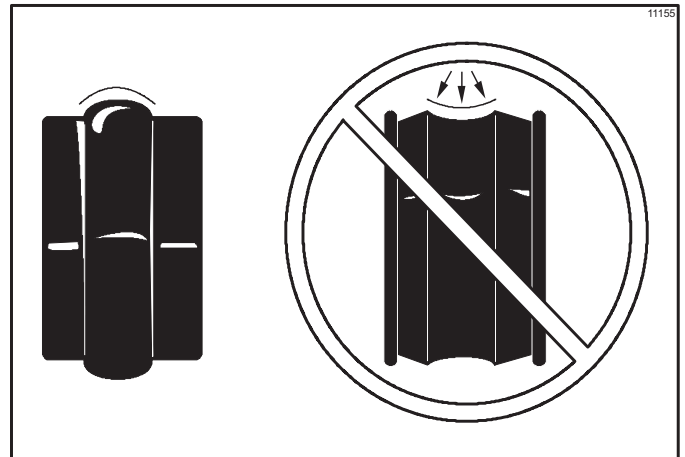

Figure 6-2

2. Lubricate the boot seal groove and slide the boot seal over the shaft and groove until it snaps into place. Fill the inside portion of the seal with 1/4 in. (6.35 mm) more lubricant. Install the driveshaft.

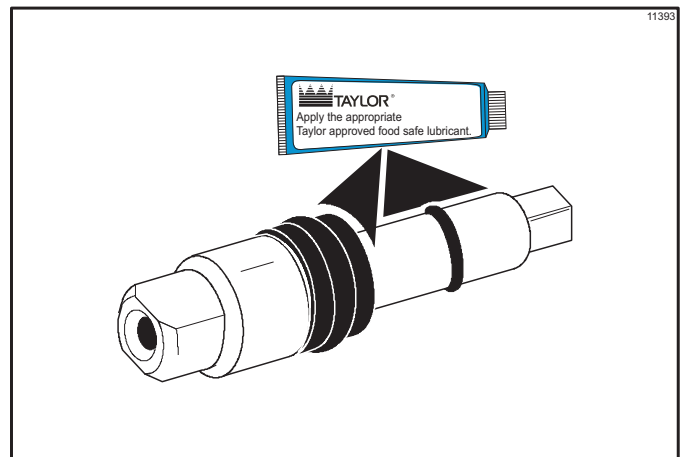

Figure 6-3

3. Insert the driveshaft into the rear shell bearing and engage the square end firmly into the female socket of the drive unit. Make sure the driveshaft fits into the drive coupling without binding.

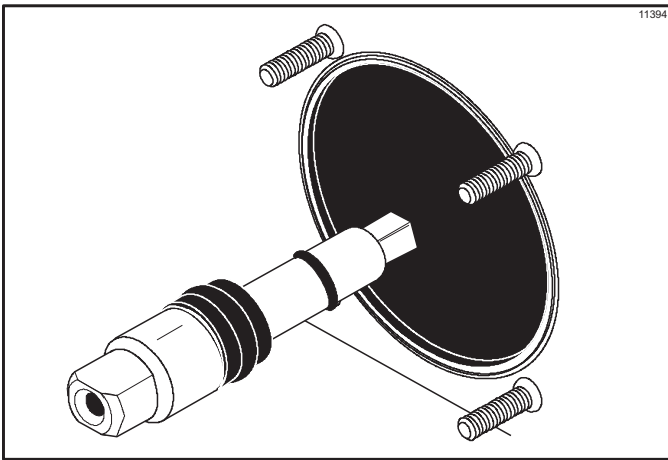

Figure 6-4



**WARNING!** Use extreme caution when handling the beater assembly. The scraper blades are very sharp and may cause injury.

- Before installing the beater assembly, inspect the scraper blades.

Check the scraper blades for any signs of wear or damage. If a scraper blade is nicked or worn, replace both blades.

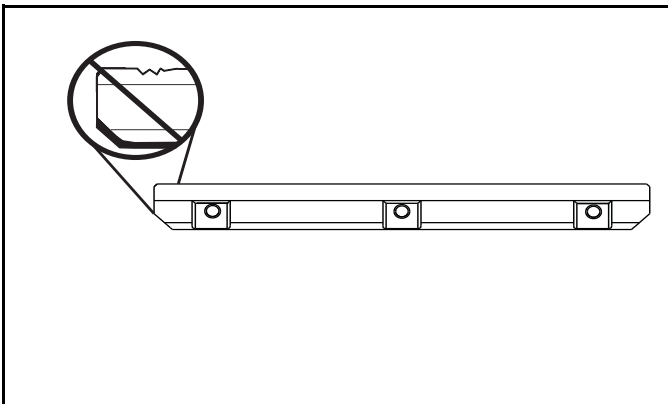

Figure 6-5

- If the blades are in good condition, place the rear scraper blade over the rear holding pin (knife edge to the outside). Holding the blade on the beater, turn it over and install the front blade the same way.

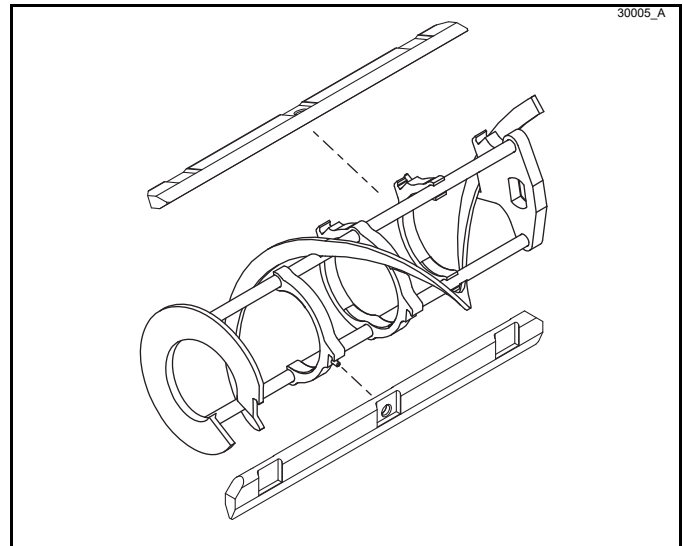

Figure 6-6

**Note:** The hole on the scraper blade must fit securely over the pin to prevent damage.

- Holding the blades in position, insert the beater assembly into the freezing cylinder and slide the assembly into position over the driveshaft. Turn the beater slightly to make sure that the beater is properly seated. When in position, the beater will not protrude beyond the front of the freezing cylinder.

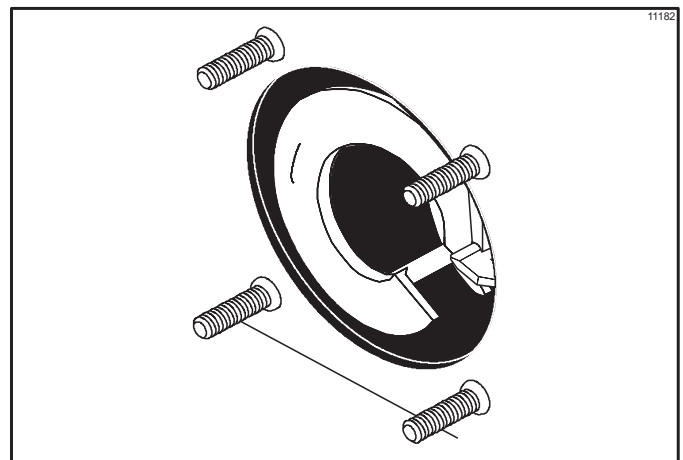

Figure 6-7

- Install the white plastic guide bearing on the short end of the torque rotor. Slide the O-ring into the groove on the long end of the torque rotor and lubricate the O-ring. Do not lubricate the guide bearing.

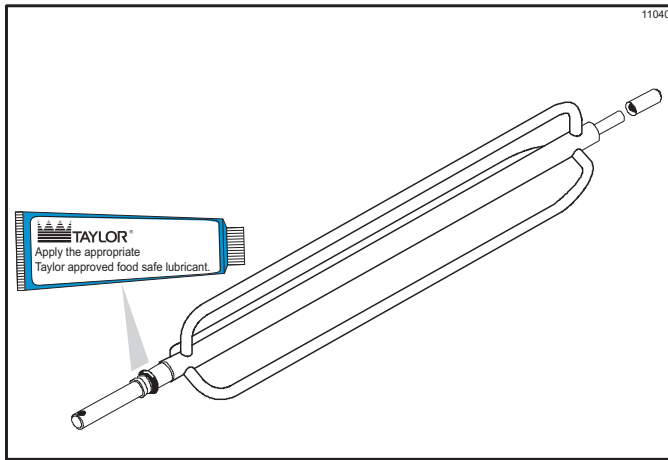

Figure 6-8

8. Insert the torque rotor with the guide bearing end into the pilot hole in the center of the driveshaft. The hole in the torque rotor shaft should be rotated to the 12 o'clock position.

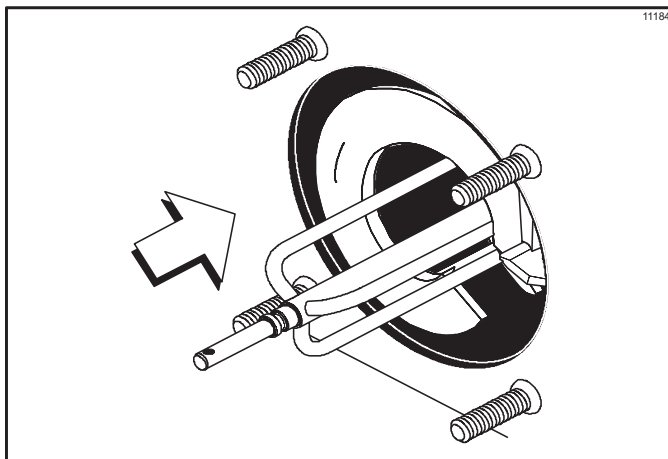

Figure 6-9

9. Before assembling the freezer door, check the following for any nicks, cracks, or signs of wear: front bearing, door gasket, draw valve, O-rings, and all sides of the door assembly, including the inside of the draw valve bore. Replace any damaged parts.

**Freezer Door Assembly—Standard Door (No Prime Plug)**

**Note:** The Model 428 comes equipped with two door options: a standard door without a prime plug, or a self-closing door with a prime plug. Follow the appropriate assembly procedures for your style door. (For self-closing/prime plug door assembly instructions, go to page 6-5 and perform steps a through o.)

10. Install the O-rings on the draw valve and lubricate.

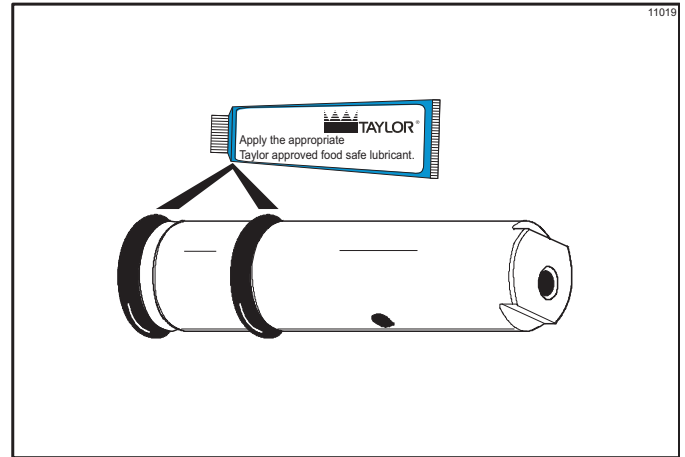

Figure 6-10

11. Insert the draw valve into the door, leaving approximately 1/2 in. (12.7 mm) of the valve sticking out the top of the door.

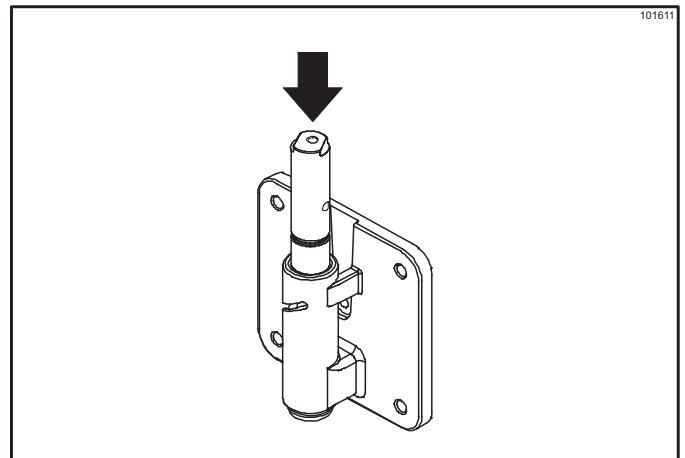

Figure 6-11

12. Rotate the draw valve so the flats on the top of the draw valve are perpendicular to the door face.

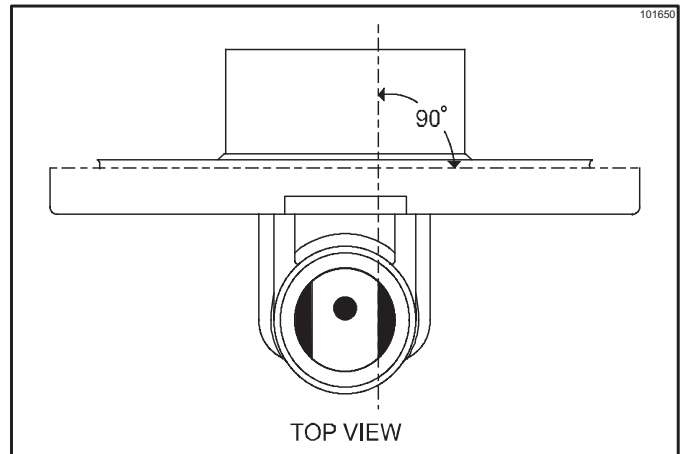

Figure 6-12

## OPERATING PROCEDURES

13. Insert the ice buster through the door spout and into the slot located just above the lower O-ring.

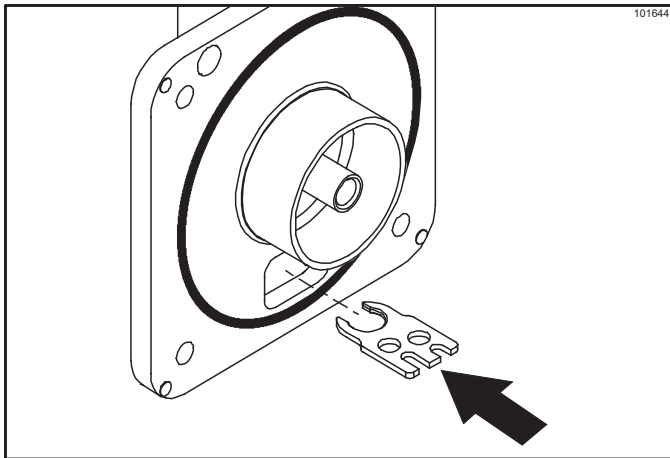

Figure 6-13

14. With the ice buster in place, rotate the draw valve to allow installation of the draw handle. This will lock the ice buster in place. Install the draw handle pin and close the draw valve by moving the handle to the left.

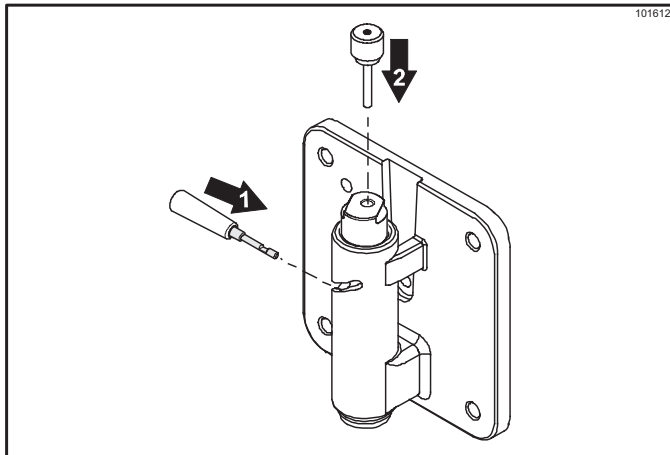

Figure 6-14

15. Place the large rubber gasket into the groove on the back side of the freezer door. Slide the white plastic front bearing onto the bearing hub, making sure that the flanged end of the bearing is resting against the freezer door. **Do not** lubricate the door gasket or front bearing.

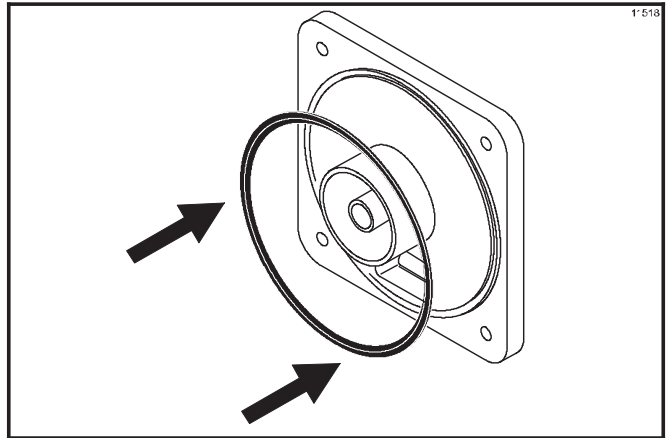

Figure 6-15

16. Position the freezer door onto the four studs on the front of the freezing cylinder. Install the handscrews. Tighten equally in a crisscross pattern to ensure the door is secure. **Do not** overtighten.
17. Position the torque arm by inserting it through the slot in the torque switch arm and down into the hole in the torque rotor, which protrudes from the door. Verify proper installation by moving the torque rotor back and forth to make sure it moves freely and easily.

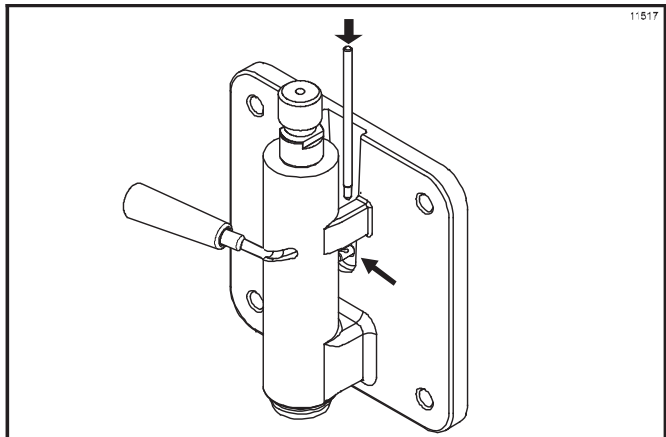

Figure 6-16

Proceed to Step 18 on page 6-8.



**Freezer Door Assembly - Self-Closing/Prime Plug Door**

**Note:** The Model 428 comes equipped with two door options: a standard door without a prime plug, or a self-closing door with a prime plug. Follow the appropriate assembly procedures for your style door. (For standard door [no prime plug] assembly instructions, go to page 6-3 and perform steps 10 through 17).

**a. Self-Closing Door Assembly**

Install the O-rings on the draw valve and lubricate.

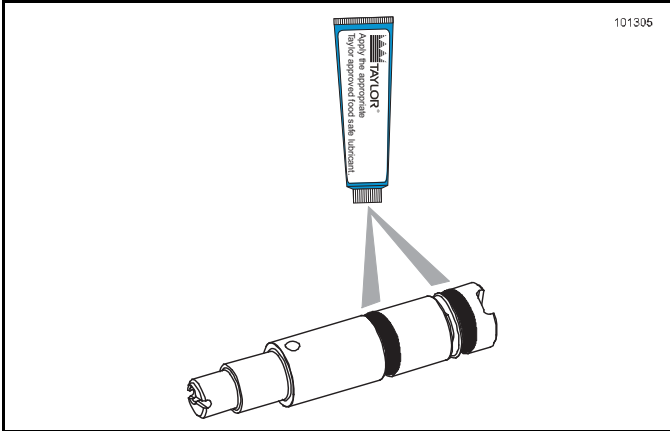

Figure 6-17

**b. Self-Closing Door Assembly**

Turn the door upside down. Insert the spring.

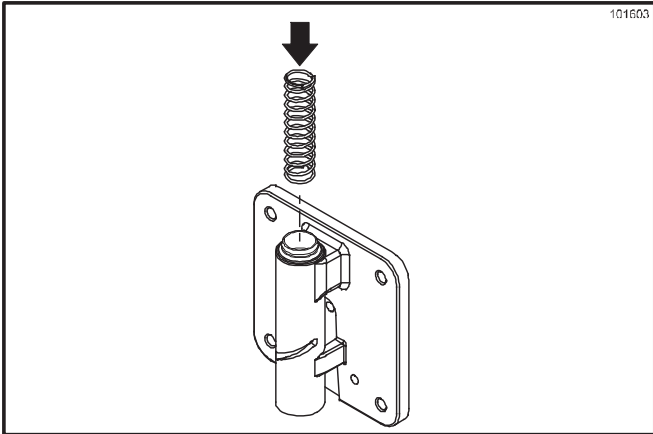

Figure 6-18

**c. Self-Closing Door Assembly**

Insert the draw valve into the door. Line up the small hole on each side of the draw valve with the slot on each side of the door spout.

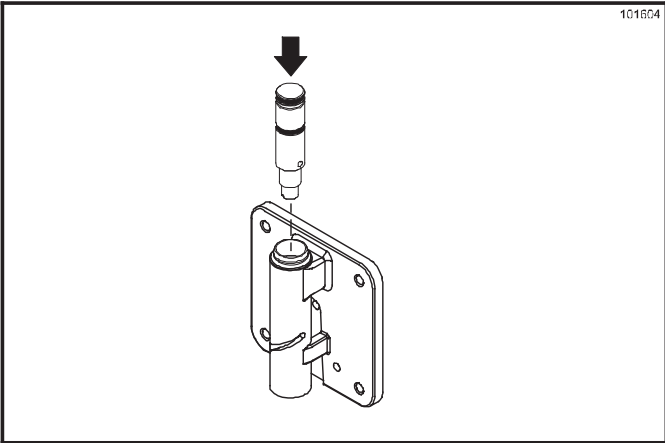

Figure 6-19

**d. Self-Closing Door Assembly**

Apply firm downward pressure on the draw valve and center the draw valve hole in the small slot on the left side of the spout. Insert the draw valve handle through the slot and into the draw valve hole.

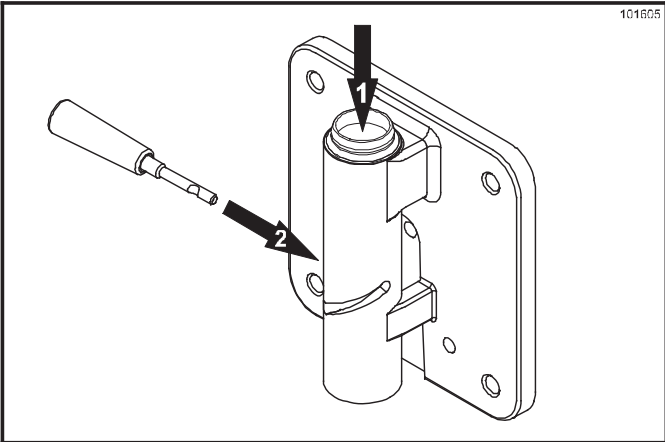

Figure 6-20

**e. Self-Closing Door Assembly**

Move the draw handle to the forward position to allow installation of the ice buster.

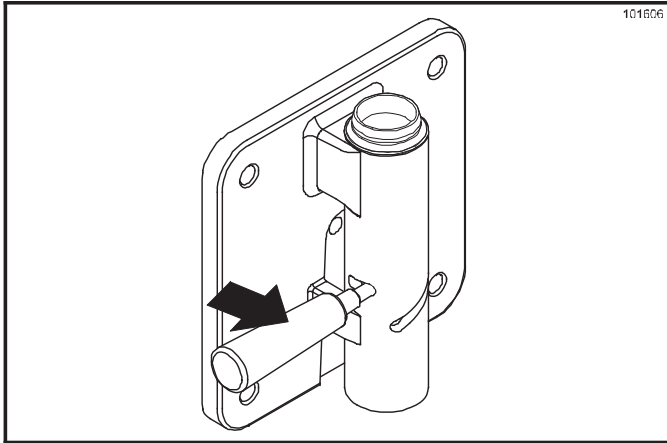

Figure 6-21

**f. Self-Closing Door Assembly**

From the back side of the door, install the ice buster through the door spout and into the slot located just above the lower O-ring.

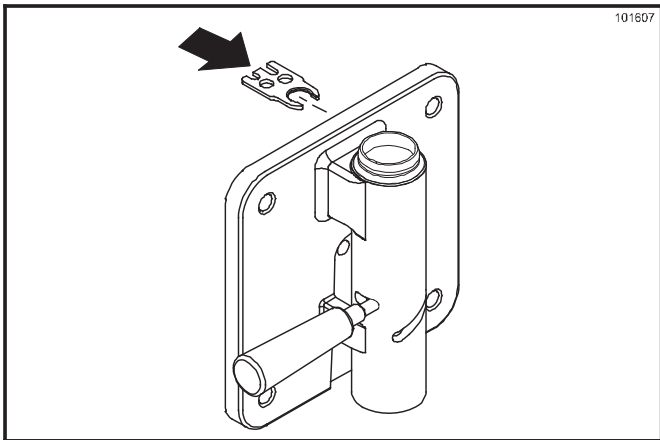

Figure 6-22

**g. Self-Closing Door Assembly**

Move the draw handle to the back position to lock the ice buster in place.

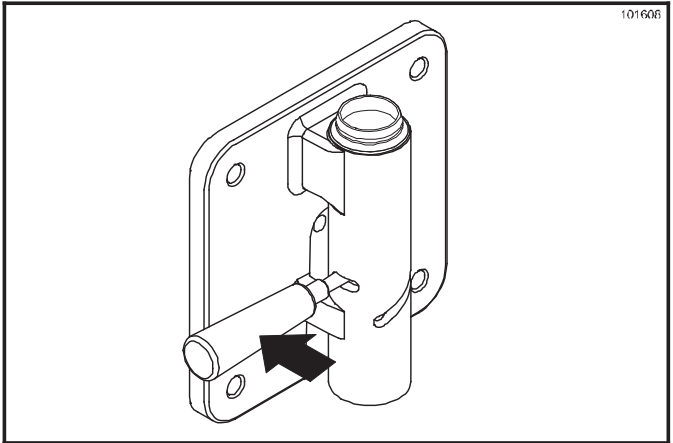

Figure 6-23

**h. Self-Closing Door Assembly**

Turn the door right side up. Remove the draw valve handle. Install it on the other side, through the longer slot and into the draw valve hole.

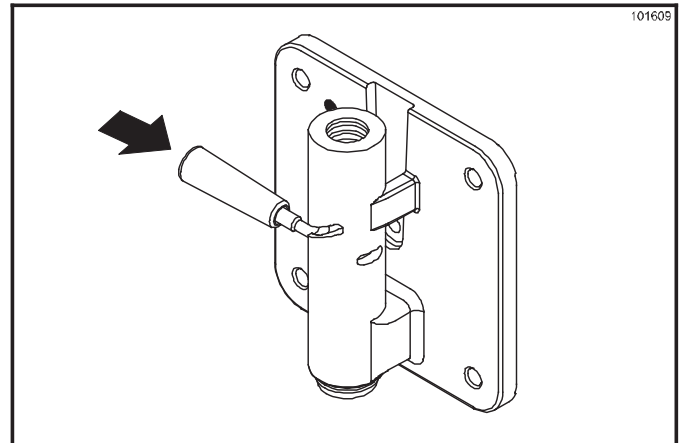

Figure 6-24

**i. Self-Closing Door Assembly**

Insert the valve handle pin. Turn the pin and the draw valve handle until the pin drops completely into place.

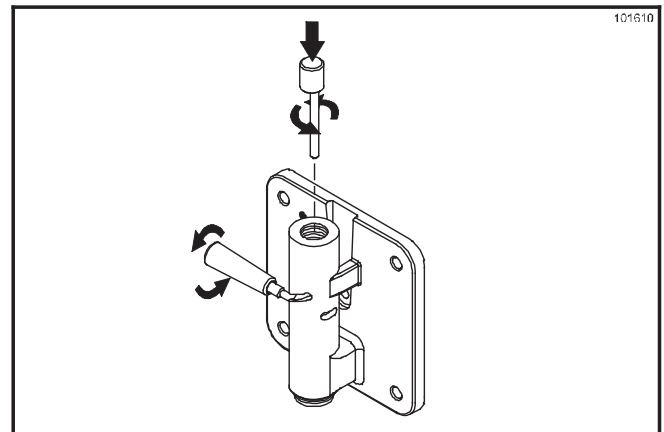

Figure 6-25

**j. Self-Closing Door Assembly**

Place the O-ring onto the prime plug and lubricate.

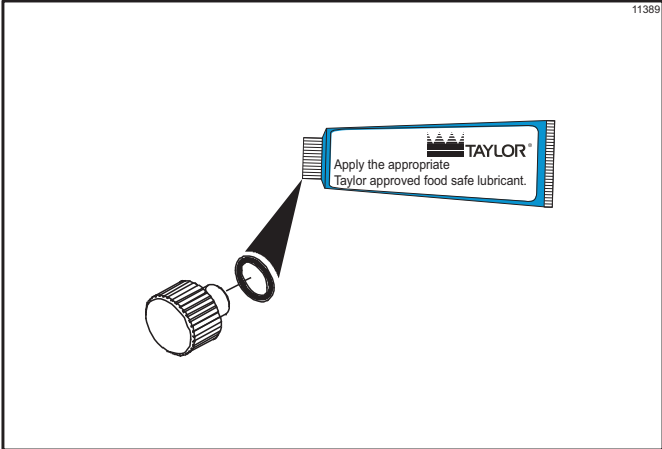

Figure 6-26

**l. Self-Closing Door Assembly**

Place the large rubber gasket into the groove on the back side of the freezer door.

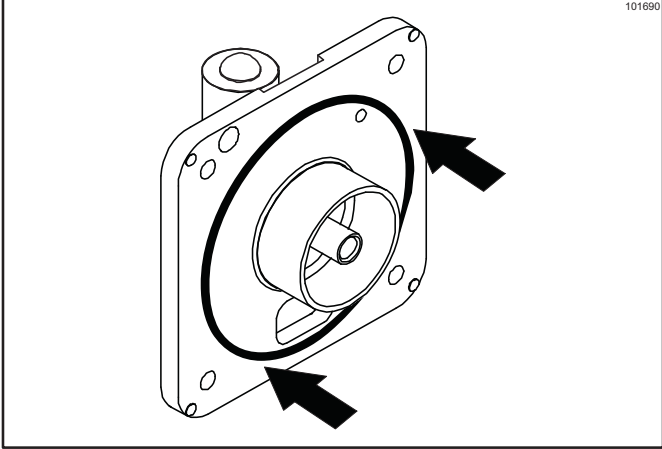

Figure 6-28

**k. Self-Closing Door Assembly**

Screw the prime plug into position on the front of the door.

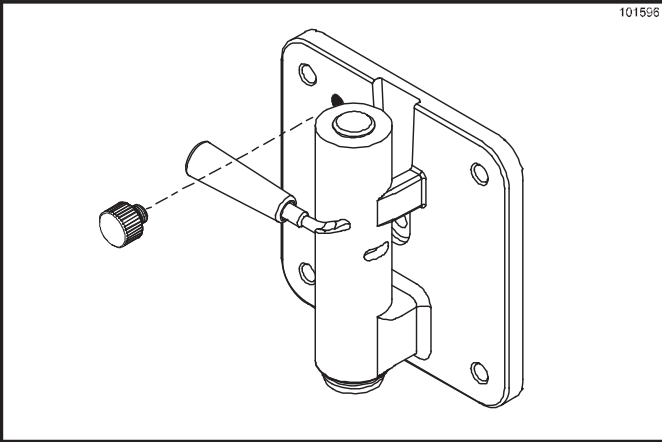

Figure 6-27

**m. Self-Closing Door Assembly**

Slide the white plastic front bearing onto the bearing hub, making sure the flanged end of the bearing is resting against the freezer door. **Do not** lubricate the door gasket or front bearing.

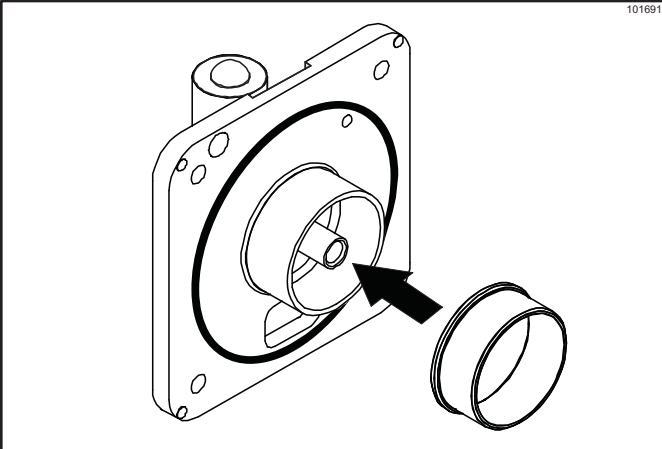

Figure 6-29

## n. Self-Closing Door Assembly

Position the freezer door onto the four studs on the front of the freezing cylinder and push the door into place. Install the four handscrews onto the studs and tighten them equally in a crisscross pattern to ensure that the door is secure. **Do not** overtighten the handscrews.

**Note:** If the freezer door does not fit into place easily, put the open end of the beater assembly in the 11 o'clock position.

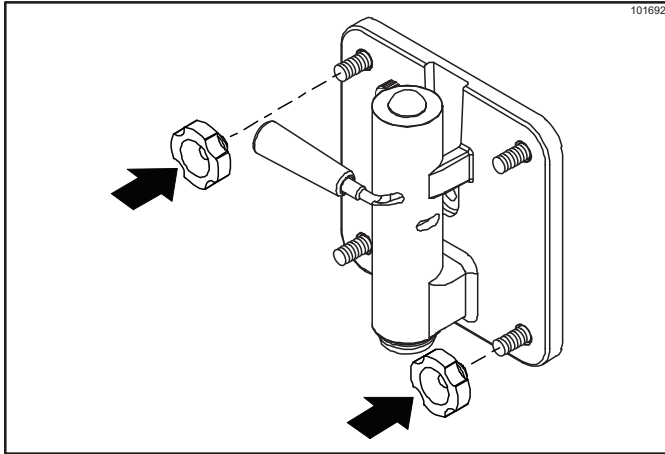

Figure 6-30

## o. Self-Closing Door Assembly

Position the torque arm by inserting it down into the hole on the torque rotor, which protrudes from the door. Verify proper installation by moving the torque rotor back and forth to make sure it moves freely.

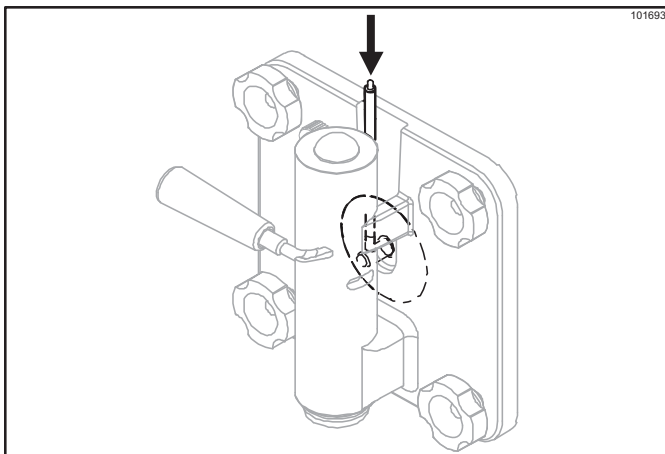

Figure 6-31

Proceed to Step 18.

18. Install the front drip pan: Slide the long drip pan into the hole in the front panel.

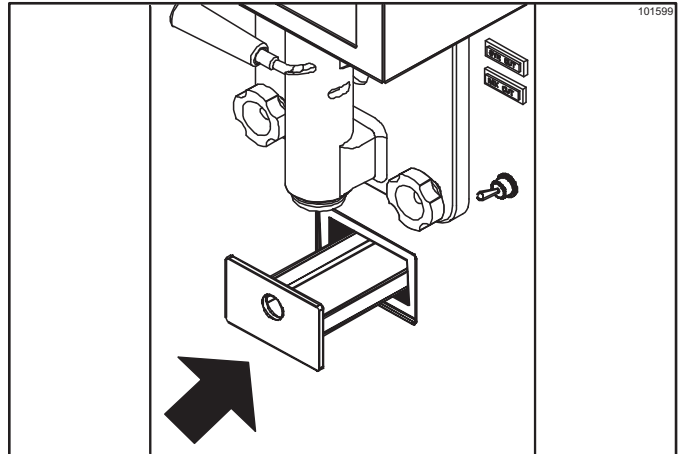

Figure 6-32

19. Install the front drip tray and splash shield beneath the door spout.

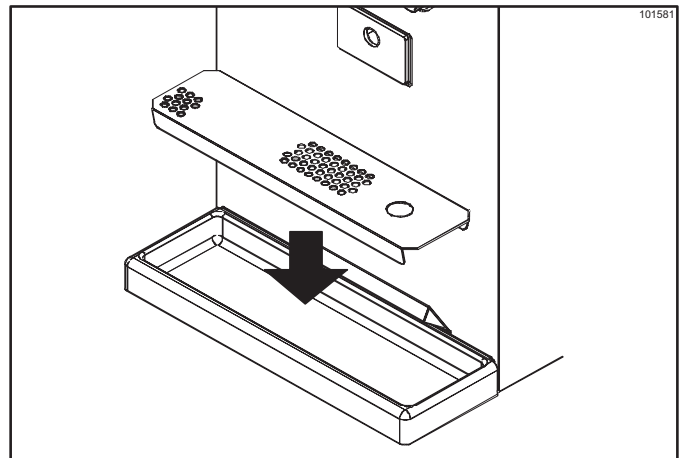

Figure 6-33

20. Lay the air/mix feed tube (optional) in the bottom of the mix hopper.

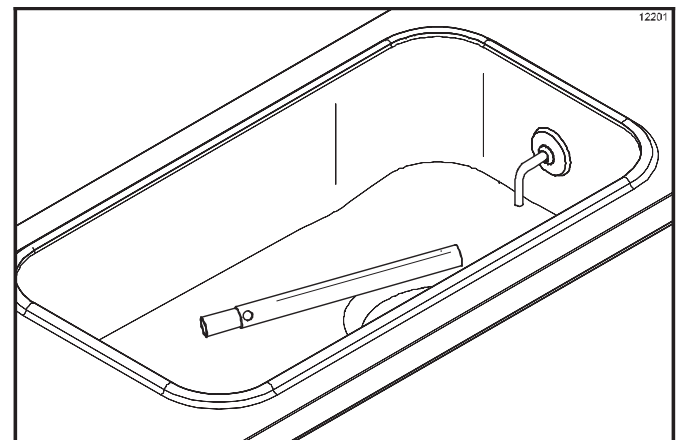

Figure 6-34

## Sanitizing

1. Prepare an approved 100 ppm sanitizing solution (examples: 2-1/2 gal. [9.5 L] of Kay-5<sup>®</sup> or 2 gal. [7.6 L] of Stera-Sheen<sup>®</sup>). Use warm water and follow the manufacturer's specifications.
2. Pour the sanitizing solution into the hopper and allow it to flow into the freezing cylinder.

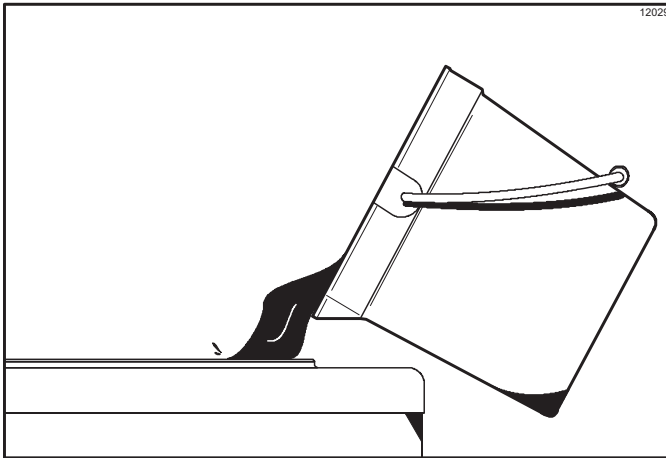

Figure 6-35

3. While the solution is flowing into the freezing cylinder, brush-clean the mix hopper, air/mix feed tube (optional), and mix inlet hole.
4. Place the power switch in the WASH position. This will agitate the sanitizing solution in the freezing cylinder. Allow the solution to agitate for 5 minutes.

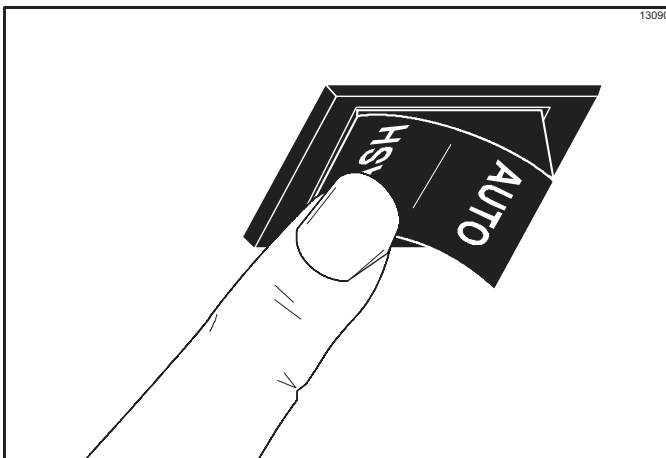

Figure 6-36

5. Place an empty pail beneath the door spout and move the draw handle to the right. Draw off all the sanitizing solution. When the sanitizer stops flowing from the door spout, move the draw handle to the left and place the power switch in the OFF position.

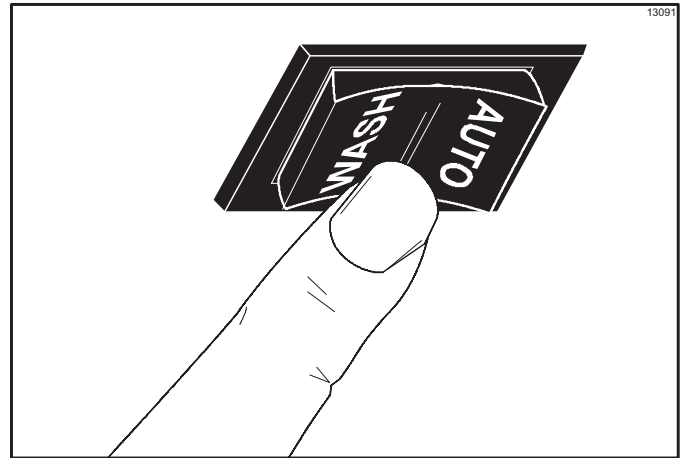

Figure 6-37

**Important!** The machine must **not** be placed in AUTO until all sanitizing solution has been removed from the freezing cylinder and proper priming procedures have been completed. Failure to follow this instruction may result in damage to the freezing cylinder.

6. With sanitized hands or a plastic, sanitized glove, stand the air/mix feed tube (optional) in the corner of the hopper.

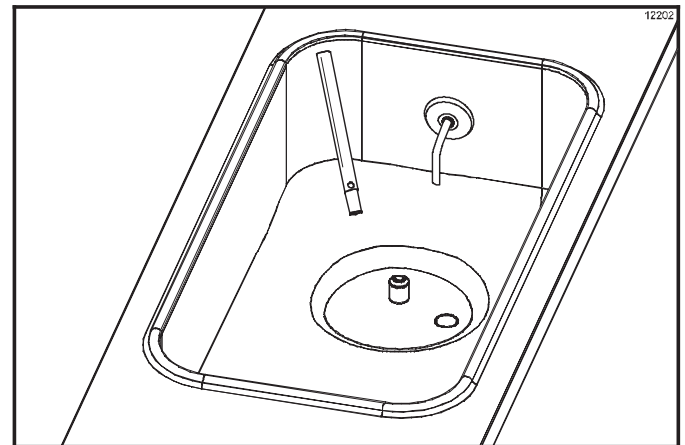

Figure 6-38

## Priming the Freezing Cylinder

1. With a pail beneath the door spout, open the draw valve. Pour 2 gal. (7.6 L) of **fresh** mix into the hopper and allow it to flow into the freezing cylinder. This will force out any remaining sanitizing solution. When full-strength product is flowing from the door spout, move the draw valve to the left.

**Important!** Failure to remove all sanitizing solution may result in damage to the freezing cylinder.

2. When mix has stopped bubbling down into the freezing cylinder, install the air/mix feed tube (optional) in the mix inlet hole with the hole side down.

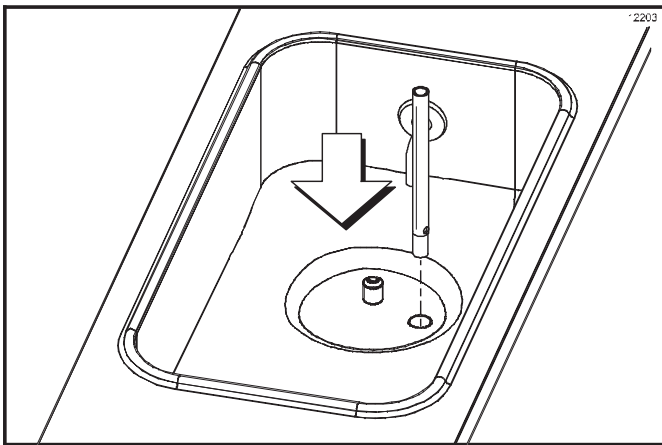

Figure 6-39

3. Place the power switch in the AUTO position. When the machine cycles off, the product will be at serving viscosity. The viscosity (thickness) of the product can be adjusted by turning the viscosity adjustment screw on the upper right side under the display light. Turn the viscosity adjustment screw clockwise for a thicker product, or counterclockwise for a thinner product. After making an adjustment, the refrigeration system must cycle two or three times to accurately evaluate the viscosity.



Figure 6-40

4. **Self-Closing Door Only:** Loosen the prime plug. When product starts to leak from the bleed port, tighten the prime plug. Allow product to continue filling the mix hopper until the upper mix-level probe is satisfied and the fill system shuts off.

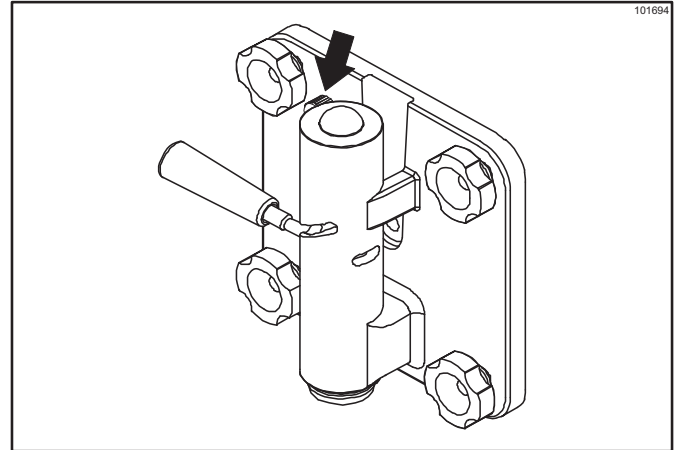

5. Place the mix hopper cover in position. For proper operation, there must be a substantial amount of mix in the hopper. If the ADD MIX light illuminates, refill the mix hopper as soon as possible.

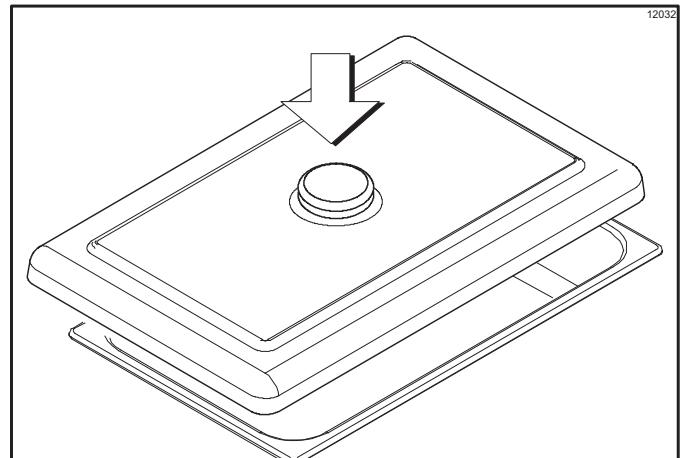

Figure 6-41

## Closing Procedure

To disassemble this machine, the following items will be needed:

- Two cleaning pails
- Cleaning brushes (provided with freezer)
- Cleaner
- Single-service towels

## Draining Product from the Freezing Cylinder

1. Place the power switch in the OFF position as far ahead of cleaning time as possible to allow frozen product to soften for easier cleaning.
2. Remove the hopper cover and the air/mix feed tube (if the machine is equipped with an air/mix feed tube). Take these parts to the sink for cleaning.
3. **If local health codes permit the use of rerun**, place a sanitized, NSF-approved stainless-steel rerun container beneath the door spout. Place the power switch in the WASH position and move the draw handle to the right. When product stops flowing from the door spout, move the draw handle to the left and place the power switch in the OFF position. Put the sanitized lid on the rerun container and place it in the walk-in cooler.

**Note:** If local health codes **do not** permit the use of rerun, **the product must be discarded**. Drain the product into a pail and properly discard it.



## Rinsing

1. Pour 2 gal. (7.6 L) of cool, clean water into the mix hopper. With the brushes provided, scrub the mix hopper, float switch, and mix inlet hole.

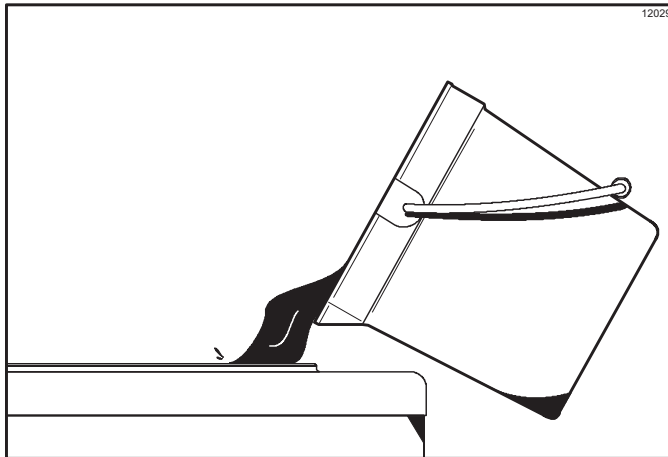

Figure 6-42

2. With a pail beneath the door spout, place the power switch in the WASH position and move the draw handle to the right. Drain all the rinse water from the freezing cylinder. When the rinse water stops flowing from the door spout, move the draw handle to the left

and place the power switch in the OFF position.

**Repeat this procedure** until the rinse water being drawn from the freezing cylinder is clear.

## Cleaning

1. Prepare an approved 100 ppm cleaning solution (examples: 2-1/2 gal. [9.5 L] of Kay-5<sup>®</sup> or 2 gal. [7.6 L] of Stera-Sheen<sup>®</sup>). Use warm water and follow the manufacturer's specifications.
2. Pour the cleaning solution into the hopper and allow it to flow into the freezing cylinder.
3. While the solution is flowing into the freezing cylinder, brush-clean the mix hopper, float switch, and mix inlet hole.
4. Place the power switch in the WASH position. This will agitate the cleaning solution in the freezing cylinder.
5. Place an empty pail beneath the door spout and move the draw handle to the right. Draw off all the cleaning solution. When the solution stops flowing from the door spout, move the draw handle to the left and place the power switch in the OFF position.

## Disassembly



**WARNING!** Make sure the power switch is in the OFF position. Failure to follow this instruction may result in severe personal injury from hazardous moving parts.

1. Remove the torque arm, handscrews, freezer door, torque rotor, beater assembly, scraper blades, and driveshaft from the freezing cylinder. Take these parts to the sink for cleaning.
2. Remove the front drip tray and the splash shield. Take these parts to the sink for cleaning.
3. Remove the rear drip pan from the front panel.

**Note:** If the drip pan is filled with an excessive amount of mix, the driveshaft seal should be replaced or properly lubricated.

### Brush-Cleaning

1. Prepare a sink with a cleaning/sanitizing solution with an active chlorine concentrate of 100 to 200 ppm. (examples: Kay-5<sup>®</sup> or Stera-Sheen<sup>®</sup>). Use warm water and follow the manufacturer's specifications. (If another approved cleaner is used, dilute according to label instructions.)

**Important!** Follow the label directions. Too **strong** of a solution can cause parts damage, while too **mild** of a solution will not provide adequate cleaning. Make sure all brushes provided with the freezer are available for brush-cleaning.

2. Remove the O-ring and seal from the driveshaft. Remove the O-ring and the bearing from the torque rotor.
3. Remove the draw handle, draw valve, ice buster, front bearing, prime plug, freezer door, and gasket from the freezer door. Remove the spring and prime plug (self-closing door only). Remove all O-rings.

**Note:** To remove an O-ring, use a single-service towel to grasp the O-ring. Apply pressure upward until the O-ring pops out of its groove. With the other hand, push the top of the O-ring forward until it rolls out of the groove and can be easily removed.

4. Thoroughly brush-clean all disassembled parts in the cleaning solution, making sure all lubricant and mix film is removed. Place all the cleaned parts on a clean, dry surface to air-dry.
5. Return to the freezer with a small amount of cleaning solution. Brush-clean the rear shell bearing at the back of the freezing cylinder with the black bristle brush.

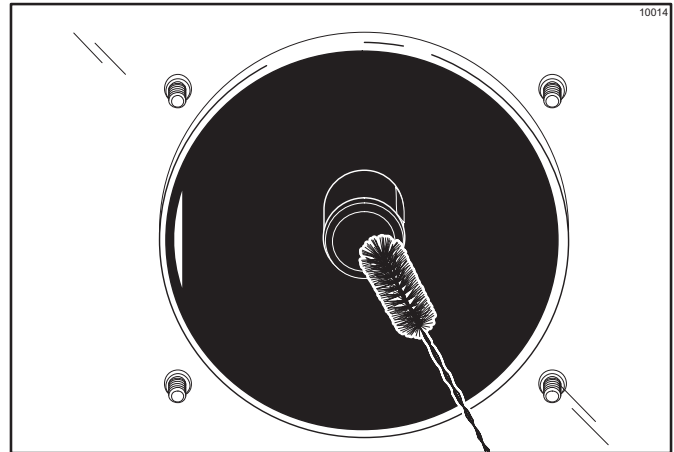

Figure 6-43

6. Wipe clean all exterior surfaces of the freezer.



## During Cleaning and Sanitizing



**NOTICE!** Cleaning and sanitizing schedules are governed by federal, state, or local regulatory agencies and must be followed accordingly. If the machine has a Standby mode, it must not be used in lieu of proper cleaning and sanitizing procedures and frequencies set forth by the ruling health authority. The following checkpoints should be stressed during the cleaning and sanitizing operations.



**IMPORTANT!** *Cleaning and sanitizing must be performed daily.*

## Troubleshooting Bacterial Count

- Thoroughly clean and sanitize the machine regularly, including complete disassembly and brush-cleaning.
- Use all brushes supplied for thorough cleaning. The brushes are specially designed to reach all mix passageways
- Use the white bristle brush to clean the mix feed tube, which extends from the hopper down to the rear of the freezing cylinder.
- Use the black bristle brush to thoroughly clean the rear shell bearing at the rear of the freezing cylinder. Use a generous amount of cleaning solution on the brush.
- If local health codes permit the use of rerun,** make sure it is stored in a sanitized, covered stainless-steel container and used the following day. **Do not** prime the machine with rerun. When using rerun, skim off the foam and discard, then add **fresh** mix in a ratio of 50:50 during the day's operation.

- On a designated day of the week, run the mix as low as feasible and discard after closing. This will break the rerun cycle and reduce the possibility of high bacteria and coliform counts.
- Properly prepare the cleaning and sanitizing solutions. Read and follow label directions carefully. Too **strong** of a solution may damage the parts, and too **weak** of a solution will not do an adequate job of cleaning or sanitizing.
- Temperature of mix in mix hopper and walk-in cooler should be below 40°F (4.4°C).

## Regular Maintenance Checks

- Replace scraper blades that are nicked, damaged, or worn down. Before installing the beater, make sure the scraper blades are properly attached.
- Check rear shell bearing for signs of wear (excessive mix leakage in drip pan) and make sure it is properly cleaned.
- Using a screwdriver and cloth towel, clean the rear shell bearing and the female square drive socket of lubricant and mix deposits.
- Dispose of O-rings and seals if they are worn, torn, or fit too loosely, and replace them with new ones.
- Follow all lubricating procedures as outlined in Assembly on page 6-1.
- Check the condenser(s) for dirt and lint. Dirty condensers will reduce the efficiency and capacity of the machine. Condensers should be cleaned **monthly** with a soft brush. **Never** use screwdrivers or other metal probes to clean between the fins.

**Note:** *For machines equipped with an air filter, it will be necessary to vacuum-clean the filters monthly.*

### Winter Storage

If the place of business is to be closed during the winter months, it is important to protect the freezer by following certain precautions, particularly if the building is to be left unheated and subject to freezing conditions. Disconnect the freezer from the main power source to prevent possible electrical damage. Your local Taylor distributor can perform this service for you.

Wrap detachable parts of the freezer (such as beater, blades, driveshaft, and freezer door) and place in a protected dry place. Rubber trim parts and gaskets can be protected by wrapping with moisture-proof paper. All parts should be thoroughly cleaned of dried mix or lubrication accumulations, which can attract mice and other vermin.

Table 8-1

Problem	Probable Cause	Remedy	Page Ref.
1. No product is being dispensed.	a. Power switch is in the OFF position.	a. Place power switch in the AUTO position.	6-10
	b. Improper mixing of product.	b. Carefully follow directions for mixing product.	---
	c. Inadequate mix in hopper.	c. Fill hopper with mix.	6-10
	d. Product frozen in freezing cylinder.	d. Adjust viscosity adjustment accordingly.	5-2
	e. Machine out on reset.	e. Place power switch in the OFF position. Press the RESET button. Return power switch to AUTO.	5-2
	f. Beater assembly is not rotating at all or counterclockwise. Power switch is not in AUTO.	f. The power switch must be in AUTO. If beater is rotating counterclockwise, call a service technician to correct rotation.	1-3
	g. Machine unplugged at wall receptacle.	g. Plug in power cord.	---
	h. Tripped circuit breaker or blown fuse.	h. Reset circuit breaker or replace fuse.	---
2. Machine will not operate in the Auto or Wash mode.	a. Machine unplugged at the wall receptacle.	a. Plug in the power cord.	---
	b. Tripped circuit breaker or blown fuse.	b. Reset circuit breaker or replace fuse.	---
	c. Machine out on reset.	c. Place the power switch in the OFF position. Press the RESET button. Return power switch to AUTO.	5-2
3. No compressor operation in Auto mode.	a. Beater motor is out on overload.	a. Place power switch in the OFF position. Press the RESET button. Return power switch to AUTO.	5-2
	b. Condenser dirty (air-cooled machines).	b. Clean condenser monthly.	7-1
4. Product too thick.	a. Inadequate mix in hopper.	a. Fill hopper with mix.	6-10
	b. Improper mixing of product.	b. Carefully follow directions for mixing product.	---
	c. The viscosity adjustment is set incorrectly.	c. Adjust the viscosity control.	5-2
	d. The torque arm is not installed.	d. Install the torque arm.	6-3

## TROUBLESHOOTING GUIDE

Problem	Probable Cause	Remedy	Page Ref.
5. Product too thin.	a. Missing, incorrectly installed, or bad scraper blade.	a. Install or replace scraper blade.	6-2
	b. Improper mixing of product.	b. Carefully follow directions for mixing product.	---
	c. The viscosity adjustment is set incorrectly.	c. Adjust accordingly.	5-2
	d. Incorrect beater rotation.	d. Contact a service technician.	---
	e. Dirty condensers.	e. Clean regularly.	7-1
6. The freezing cylinder walls are scored.	a. The scraper blades are damaged.	a. Replace the scraper blades.	6-2
	b. Missing or worn front bearing on freezer door.	b. Install or replace the front bearing.	6-7
	c. Machine was placed in Auto before all sanitizing solution was removed from freezing cylinder.	c. Place machine in Auto only after priming is complete and all sanitizing solution is removed.	6-10
	d. The beater assembly is bent.	d. Call a service technician to repair or replace the beater and to correct the cause of insufficient mix in the freezing cylinder.	---
7. Excessive leakage into rear drip pan.	a. Improper or inadequate lubrication of driveshaft seal.	a. Use correct lubricant (Taylor Lube) and follow lubrication procedures.	6-1
	b. Bad or missing seal on driveshaft.	b. Replace seal every 3 months.	9-1
	c. Worn rear shell bearing.	c. Contact a service technician for replacement.	---
	c. Seal is installed inside out.	c. Install the seal correctly.	6-1
8. Excessive leakage from door spout.	a. Improper or inadequate lubrication of draw valve O-rings.	a. Use correct lubricant (Taylor Lube) and follow lubrication procedures.	6-1
	b. Bad or missing O-rings on draw valve.	b. Replace O-rings every 3 months.	6-3 9-1
9. Unable to remove driveshaft.	a. Lubricant on square end of driveshaft.	a. Do not lubricate square end. Contact service technician for replacement.	6-1
	b. Rounded corners of driveshaft, drive coupling, or both.	b. Contact a service technician to replace driveshaft, drive coupling, or both.	---

Table 9-1

Part Description	Every 3 Months	Every 6 Months	Annually	Quantities to Be Replaced
Driveshaft Seal	X			1
Driveshaft O-ring	X			1
Scraper Blade	X			1
Freezer Door Gasket	X			1
Front Bearing	X			1
Guide Bearing	X			1
Draw Valve O-rings	X			2
Black Bristle Brush—1" x 2"		Inspect and replace if necessary.	Minimum	1
White Bristle Brush—3" x 7"		Inspect and replace if necessary.	Minimum	1
White Bristle Brush—1" X 2" X 17"		Inspect and replace if necessary.	Minimum	1
Double-Ended Brush		Inspect and replace if necessary.	Minimum	1
Syrup Port Brush		Inspect and replace if necessary.	Minimum	1
White Bristle Brush—1-1/2" x 2"		Inspect and replace if necessary.	Minimum	1



## TAYLOR COMPANY LIMITED WARRANTY ON FREEZERS

Taylor Company is pleased to provide this limited warranty on new Taylor-branded freezer equipment available from Taylor to the market generally (the "Product") to the original purchaser only.

### LIMITED WARRANTY

Taylor warrants the Product against failure due to defect in materials or workmanship under normal use and service as follows. All warranty periods begin on the date of original Product installation. If a part fails due to defect during the applicable warranty period, Taylor, through an authorized Taylor distributor or service agency, will provide a new or remanufactured part, at Taylor's option, to replace the failed defective part at no charge for the part. Except as otherwise stated herein, these are Taylor's exclusive obligations under this limited warranty for a Product failure. This limited warranty is subject to all provisions, conditions, limitations, and exclusions listed below and on the reverse (if any) of this document.

Table 10-1

Product	Part	Limited Warranty Period
<b>Soft Serve</b>	Insulated shell assembly	Five (5) years
<b>Frozen Yogurt Shakes</b>	Refrigeration compressor (except service valve)	Five (5) years
<b>Smoothies</b>	Beater motors	Two (2) years
<b>Frozen Beverage</b>	Beater drive gear	Two (2) years
<b>Batch Desserts</b>	Printed circuit boards and Softech™ controls beginning with serial number H8024200	Two (2) years
	Parts not otherwise listed in this table or excluded below	One (1) years

### LIMITED WARRANTY CONDITIONS

1. If the date of original installation of the Product cannot be verified, then the limited warranty period begins ninety (90) days from the date of Product manufacture (as indicated by the Product serial number). Proof of purchase may be required at time of service.
2. This limited warranty is valid only if the Product is installed and all required service work on the Product is performed by an authorized Taylor distributor or service agency, and only if genuine, new Taylor parts are used.
3. Installation, use, care, and maintenance must be normal and in accordance with all instructions contained in the Taylor Operator's Manual.
4. Defective parts must be returned to the authorized Taylor distributor or service agency for credit.
5. The use of any refrigerant other than that specified on the Product's data label will void this limited warranty.

# LIMITED WARRANTY ON EQUIPMENT

---

## LIMITED WARRANTY EXCEPTIONS

This limited warranty does **not** cover:

1. Labor or other costs incurred for diagnosing, repairing, removing, installing, shipping, servicing, or handling of defective parts, replacement parts, or new Products.
2. Normal maintenance, cleaning, and lubrication as outlined in the Taylor Operator's Manual, including cleaning of condensers.
3. Replacement of wear items designated as Class "000" parts in the Taylor Operator's Manual.
4. External hoses, electrical power supplies, and machine grounding.
5. Parts not supplied or designated by Taylor, or damages resulting from their use.
6. Return trips or waiting time required because a service technician is prevented from beginning warranty service work promptly upon arrival.
7. Failure, damage, or repairs due to faulty installation, misapplication, abuse, no or improper servicing, unauthorized alteration, or improper operation or use as indicated in the Taylor Operator's Manual, including but not limited to the failure to use proper assembly and cleaning techniques, tools, or approved cleaning supplies.
8. Failure, damage, or repairs due to theft, vandalism, wind, rain, flood, high water, water, lightning, earthquake, or any other natural disaster, fire, corrosive environments, insect or rodent infestation, or other casualty, accident or condition beyond the reasonable control of Taylor; operation above or below the electrical or water supply specification of the Product; or components repaired or altered in any way so as, in the judgment of the Manufacturer, to adversely affect performance, or normal wear or deterioration.
9. Any Product purchased over the Internet.
10. Failure to start due to voltage conditions, blown fuses, open circuit breakers, or damages due to the inadequacy or interruption of electrical service.
11. Electricity or fuel costs, or increases in electricity or fuel costs from any reason whatsoever.
12. Damages resulting from the use of any refrigerant other than that specified on the Product's data label will void this limited warranty.
13. Any cost to replace, refill, or dispose of refrigerant, including the cost of refrigerant.
- 14. ANY SPECIAL, INDIRECT, OR CONSEQUENTIAL PROPERTY OR COMMERCIAL DAMAGE OF ANY NATURE WHATSOEVER.** Some jurisdictions do not allow the exclusion of incidental or consequential damages, so this limitation may not apply to you.

This limited warranty gives you specific legal rights, and you may also have other rights which vary from jurisdiction to jurisdiction.

## LIMITATION OF WARRANTY

**THIS LIMITED WARRANTY IS EXCLUSIVE AND IS IN LIEU OF ALL OTHER WARRANTIES, CONDITIONS, AND/OR REMEDIES UNDER THE LAW, INCLUDING ANY IMPLIED WARRANTIES OR CONDITIONS OF MERCHANTABILITY OR FITNESS FOR A PARTICULAR PURPOSE. THE ORIGINAL OWNER'S SOLE REMEDY WITH RESPECT TO ANY PRODUCTS SHALL BE REPAIR OR REPLACEMENT OF DEFECTIVE COMPONENTS UNDER THE TERMS OF THIS LIMITED WARRANTY. ALL RIGHTS TO CONSEQUENTIAL OR INCIDENTAL DAMAGES (INCLUDING CLAIMS FOR LOST SALES, LOST PROFITS, PRODUCT LOSS, PROPERTY DAMAGES, OR SERVICE EXPENSES) ARE EXPRESSLY EXCLUDED. THE EXPRESS WARRANTIES MADE IN THIS LIMITED WARRANTY MAY NOT BE ALTERED, ENLARGED, OR CHANGED BY ANY DISTRIBUTOR, DEALER, OR OTHER PERSON, WHATSOEVER.**



### LEGAL REMEDIES

The owner **must** notify Taylor in writing, by certified or registered letter to the following address, of any defect or complaint with the Product, stating the defect or complaint and a specific request for repair, replacement, or other correction of the Product under warranty, mailed at least thirty (30) days before pursuing any legal rights or remedies.

Taylor Company  
750 N. Blackhawk Blvd.  
Rockton, IL 61072, U.S.A.



## TAYLOR COMPANY LIMITED WARRANTY ON TAYLOR GENUINE PARTS

Taylor Company is pleased to provide this limited warranty on new Taylor genuine replacement components and parts available from Taylor to the market generally (the "Parts") to the original purchaser only.

### LIMITED WARRANTY

Taylor warrants the Parts against failure due to defect in materials or workmanship under normal use and service as follows. All warranty periods begin on the date of original installation of the Part in the Taylor unit. If a Part fails due to defect during the applicable warranty period, Taylor, through an authorized Taylor distributor or service agency, will provide a new or remanufactured Part, at Taylor's option, to replace the failed defective Part at no charge for the Part. Except as otherwise stated herein, these are Taylor's exclusive obligations under this limited warranty for a Part failure. This limited warranty is subject to all provisions, conditions, limitations, and exclusions listed below and on the reverse (if any) of this document.

Table 11-1

Part's Warranty Class Code Or Part	Limited Warranty Period
Class 103 Parts <sup>1</sup>	Three (3) Months
Class 212 Parts <sup>2</sup>	Twelve (12) Months
Class 512 Parts	Twelve (12) Months
Class 000 Parts	No Warranty

### LIMITED WARRANTY CONDITIONS

1. If the date of original installation of the Part cannot be otherwise verified, proof of purchase may be required at time of service.
2. This limited warranty is valid only if the Part is installed and all required service work in connection with the Part is performed by an authorized Taylor distributor or service agency.
3. The limited warranty applies only to Parts remaining in use by their original owner at their original installation location in the unit of original installation.
4. Installation, use, care, and maintenance must be normal and in accordance with all instructions contained in the Taylor Operator's Manual.
5. Defective Parts must be returned to the authorized Taylor distributor or service agency for credit.
6. This warranty is not intended to shorten the length of any warranty coverage provided pursuant to a separate Taylor Limited Warranty on freezer or grill equipment.
7. The use of any refrigerant other than that specified for the unit in which the Part is installed will void this limited warranty.

<sup>1, 2</sup> Except that Taylor Part #032129SER2 (Compressor-Air-230V SERV) and Taylor Part #075506SER1 (Compressor-Air-115V 60HZ) shall have a limited warranty period of twelve (12) months when used in Taylor freezer equipment and a limited warranty period of two (2) years when used in Taylor grill equipment.

# LIMITED WARRANTY ON PARTS

---

## LIMITED WARRANTY EXCEPTIONS

This limited warranty does **not** cover:

1. Labor or other costs incurred for diagnosing, repairing, removing, installing, shipping, servicing, or handling of defective Parts, replacement Parts, or new Parts.
2. Normal maintenance, cleaning, and lubrication as outlined in the Taylor Operator's Manual, including cleaning of condensers or carbon and grease buildup.
3. Required service, whether cleaning or general repairs, to return the cooking surface assemblies, including the upper platen and lower plate, to an operational condition to achieve proper cooking or allow proper assembly of release sheets and clips as a result of grease buildup on the cooking surfaces, including but not limited to the platen and plate, sides of the shroud, or top of the shroud.
4. Replacement of cooking surfaces, including the upper platen and lower plate, due to pitting or corrosion (or in the case of the upper platen, due to loss of plating) as a result of damage due to the impact of spatulas or other small wares used during the cooking process or as a result of the use of cleaners, cleaning materials, or cleaning processes not approved for use by Taylor.
5. Replacement of wear items designated as Class "000" Parts in the Taylor Operator's Manual, as well as any release sheets and clips for the Product's upper platen assembly.
6. External hoses, electrical power supplies, and machine grounding.
7. Parts not supplied or designated by Taylor, or damages resulting from their use.
8. Return trips or waiting time required because a service technician is prevented from beginning warranty service work promptly upon arrival.
9. Failure, damage, or repairs due to faulty installation, misapplication, abuse, no or improper servicing, unauthorized alteration, or improper operation or use as indicated in the Taylor Operator's Manual, including but not limited to the failure to use proper assembly and cleaning techniques, tools, or approved cleaning supplies.
10. Failure, damage, or repairs due to theft, vandalism, wind, rain, flood, high water, water, lightning, earthquake, or any other natural disaster, fire, corrosive environments, insect or rodent infestation, or other casualty, accident, or condition beyond the reasonable control of Taylor; operation above or below the gas, electrical or water supply specification of the unit in which a part is installed; or Parts or the units in which they are installed, repaired, or altered in any way so as, in the judgment of Taylor, to adversely affect performance, or normal wear or deterioration.
11. Any Part purchased over the Internet.
12. Failure to start due to voltage conditions, blown fuses, open circuit breakers, or damages due to the inadequacy or interruption of electrical service.
13. Electricity, gas, or other fuel costs, or increases in electricity or fuel costs from any reason whatsoever.
14. Damages resulting from the use of any refrigerant other than that specified for the unit in which the Part is installed will void this limited warranty.
15. Any cost to replace, refill, or dispose of refrigerant, including the cost of refrigerant.
16. **ANY SPECIAL, INDIRECT, OR CONSEQUENTIAL PROPERTY OR COMMERCIAL DAMAGE OF ANY NATURE WHATSOEVER.** Some jurisdictions do not allow the exclusion of incidental or consequential damages, so this limitation may not apply to you.

This limited warranty gives you specific legal rights, and you may also have other rights which vary from jurisdiction to jurisdiction.

**LIMITATION OF WARRANTY**

**THIS LIMITED WARRANTY IS EXCLUSIVE AND IS IN LIEU OF ALL OTHER WARRANTIES, CONDITIONS, AND/OR REMEDIES UNDER THE LAW, INCLUDING ANY IMPLIED WARRANTIES OR CONDITIONS OF MERCHANTABILITY OR FITNESS FOR A PARTICULAR PURPOSE. THE ORIGINAL OWNER'S SOLE REMEDY WITH RESPECT TO ANY PRODUCTS SHALL BE REPAIR OR REPLACEMENT OF DEFECTIVE PARTS UNDER THE TERMS OF THIS LIMITED WARRANTY. ALL RIGHTS TO CONSEQUENTIAL OR INCIDENTAL DAMAGES (INCLUDING CLAIMS FOR LOST SALES, LOST PROFITS, PRODUCT LOSS, PROPERTY DAMAGES, OR SERVICE EXPENSES) ARE EXPRESSLY EXCLUDED. THE EXPRESS WARRANTIES MADE IN THIS LIMITED WARRANTY MAY NOT BE ALTERED, ENLARGED, OR CHANGED BY ANY DISTRIBUTOR, DEALER, OR OTHER PERSON, WHATSOEVER.**

**LEGAL REMEDIES**

The owner **must** notify Taylor in writing, by certified or registered letter to the following address, of any defect or complaint with the Part, stating the defect or complaint and a specific request for repair, replacement, or other correction of the Part under warranty, mailed at least thirty (30) days before pursuing any legal rights or remedies.

Taylor Company  
750 N. Blackhawk Blvd.  
Rockton, IL 61072, U.S.A.

